



Do-It-Yourself Manual

LPG BASED SANITARY PAD INCINERATOR



Supported by:



Powering Business Worldwide



INDEX

1. Introduction
2. Purpose of Project
3. Safety Instructions
4. Product Description
5. Features
6. Parts to make
7. Parts for purchase
8. Tools Required
9. How it Works? – LPG Based Sanitary Pad Incinerator
10. Process of Assembly
11. Commissioning of System
12. Maintenance of System
13. Disclaimer

1. Introduction

Vigyan Ashram has designed & developed a LPG Based Sanitary Pad Incinerator for Government offices, Hospitals, Ladies Hostels, Women's Club and Households. Users of the manual will be able to build their own LPG Based Sanitary Pad Incinerator using this manual. All the Bills of Materials (BOM) and dimensions of the systems are given in the design. We have provided design files drawn using Solidworks along with this manual. Users are suggested to read the manual carefully along with the site conditions before the fabrication of the unit.

Please watch following video carefully

- <https://www.youtube.com/watch?v=a2zW2NqD5V0>

2. Purpose of Manual

- To share the standardized design of LPG Based Sanitary Pad Incinerator suitable for Government offices, Hospitals, Ladies Hostels, Women’s Club and Households.
- Design to be made available online for local fabricators to build LPG Based Sanitary Pad Incinerator for their customers.



3. Safety Instructions

During fabrication of the system, we should use safety equipment such as hand gloves, shoes and glasses.



(And as appropriate)

4. Product Description

The LPG Based Sanitary Pad Incinerator consist of Back panel, heating chamber, outer jacket, insulation, regulated gas geyser system, electronics system and chimney/ exhaust system at top. Outer jacket & insulation chamber made up from 1mm thick Mild steel sheet.

The detail view and bill of materials are given below:

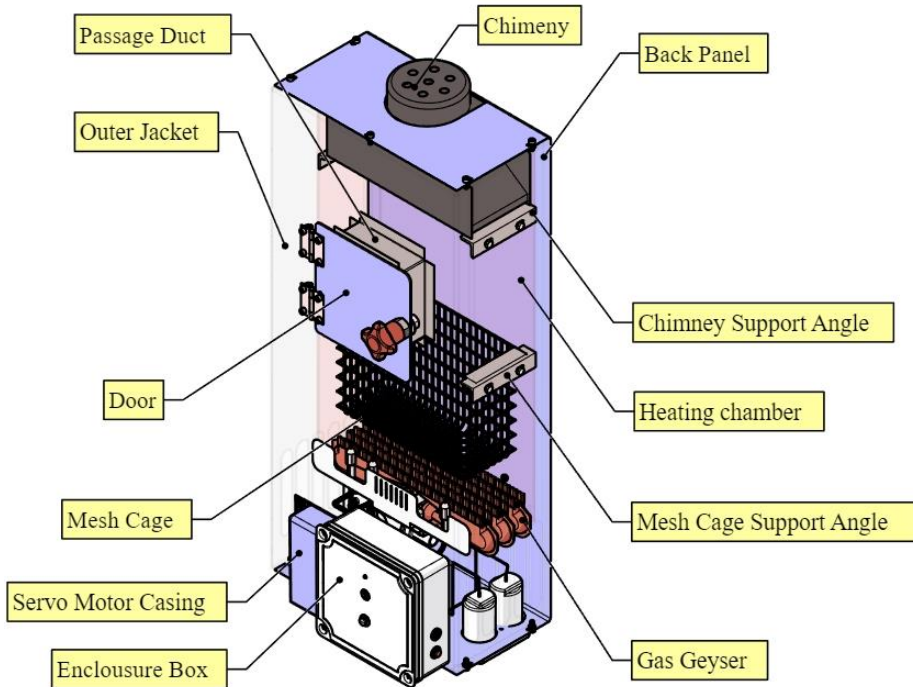

[LPG based sanitary pad Incinerator BOM](#)

[LPG based sanitary pad Incinerator BOM library](#)

5. Features

- Feed Rate @ 5 Pad/cycle.
- Cycle time of combustion process @ 6min/cycle.
- Low-cost LPG base Incinerator system.
- LPG consumption per cycle @ 15g
- Operation Cost/ cycle @ ₹. 1.95/-
- Incineration Cost/Pad @ ₹. 0.39/-
- Negligible amount of smoke output.
- Complete combustion of used pads.
- User friendly and easy to operate.
- Compact Design with minimum maintenance.
- Fully Automated Electricals controls.
- Easy to fabricate
- Focused safety

6. Parts to make

No.	Part Name	Dwg. Ref (pdf)
1	Back Panel	VA2021-P005-00-0001
2	Heating Chamber	VA2021-P005-01-0001
3	Support Angle	VA2021-P005-01-0002
4	Mesh Cage	VA2021-P005-01-0003
5	Passage Duct	VA2021-P005-01-0005
6	Outer Jacket	VA2021-P005-04-0000
7	Door Square tube Packing	VA2021-P005-04-0001-1004-02
8	Door Plate	VA2021-P005-04-0001-1004-01
9	Servo Motor Casing	VA2021-P005-04-0002-1005-01
10	Servo Motor Casing Slider	VA2021-P005-04-0002-1005-02
11	Chimney	VA2021-P005-01-0004
12	Servo Motor Stand	VA2021-P005-02-0002-1002-1

7. Parts for purchase

Sr. No.	Part Name	Specification	Qty.
1.	Arduino	UNO	1
2.	Adapter	5V, 3A	1
3.	Electric Panel Box	150*150*50 mm (PVC)	1
4.	JST XH male-female connector	4 Pin	1
		3 Pin	1
		2 Pin	4
5.	Connecting Wire	26 AWG	2m
6.	Power Jack Male-Female	2.1 x 5.5mm DC Power Jack Socket	1
7.	2 Channel Relay	5V	1
8.	Buzzer	5V	1
9.	Led	Red	1
10.	Push Button	2-Pin SPST On-Off Switch	2
11.	Wire Shrink	5mm Día	1m
12.	Gas Geyser Burner with Copper valve Ass.	H-Shaped 250mm/3 rows	1
13.	Servo Motor	MG945, 5v	1
14.	Flexible Coupling	5mm x 8mm	1
15.	Battery	1.5 V, C-Size	2

8. Tools required

Hand Grinder

Drill Machine

Power cutter

Welding
Machine

Bending
Machine

Measuring
Tape

Allen Key

Marker

Paint Brush

Vernier
Caliper

9. How it works? - LPG Based Sanitary Pad Incinerator

Disposal of used sanitary pad & similar kind of medical waste has been a very common problem. In general, the used napkins are thrown to dustbins or flush into the drain. The open disposal of soiled pads not recommended due to hygiene issues. Disposal problem is difficult due to use of gel forming polymers used in modern day's pads. It has also a taboo factor attached to further increasing complicity of disposal. Incineration of medical waste is one of the possible ways to dispose sanitary pads.

Incineration Process:

Incineration is a thermal waste treatment process that involves the combustion of organic substances contained in waste materials. Incineration of waste materials converts the waste into ash, flue gas and heat.

The proposed product is an LPG base fully Automatic Sanitary napkin incinerator. It uses LPG gas as a source of fuel for burning the pads in a very effective way using very little time of operation cycle and nearly no smoke output.

It runs on a Program Algorithmic control for all components. Which starts when we press the start button. It has 5 pads capacity for each cycle.

Insert used pads through the inlet and close the door. Push the main switch to on the device and press the start button for running the program, which is turn on the buzzer and blink of led indicator. The program is running

the algorithm in hardware (Arduino) on the relay (N₁). Further open the gas solenoid valve and make gas supply flow on. Simultaneously the second relay N₂ start the spark plugs for igniting the LPG enters and the algorithm set the servo connected to adjustable gas flow valve. Solenoid valve is controlling the opening the flame from 0° to 120°.

Within certain seconds the algorithm decreases the servo angle to 0° and make the flame small enough it not turns off and keep the pad surface in air contact. To make itself ignite for some time and form a thin cloud of air in the cavity.

Further ignition process repeated for certain number of times for operation (6 min) in the ratio of 4:12 seconds. High and low flame are burn the pads completely & converted into ash which is less than 0.1% mass of the pad. After 6 min complete the cycle of operation in the algorithm, it reset the program and gas valve became close and turning the servo at 0° for closing gas flow ensure the safety. and make ready the device for next batch.

This all process makes the LPG base sanitary napkin so effective that it makes 15 timeless CO₂, 8 times chipper to run in cost, and 5 times faster than commercial Electrical Sanitary napkin incinerator available in the market.

10. Process of Assembly

1. Back panel
2. Heating Chamber Assembly
 - a. Heating chamber
 - b. Mesh Cage Support Angle
 - c. Inserting a Mesh Cage
 - d. Chimney Support Angle
 - e. Chimney
 - f. Passage Duct
3. Regulated gas geyser system
 - a. Burner Assembly
 - b. Servo Motor Assembly
4. Outer jacket
 - a. Door Assembly
 - b. Panel box & wire fittings
 - c. Servo Motor Casing Assembly
5. Complete Assembly

10.1. Back panel

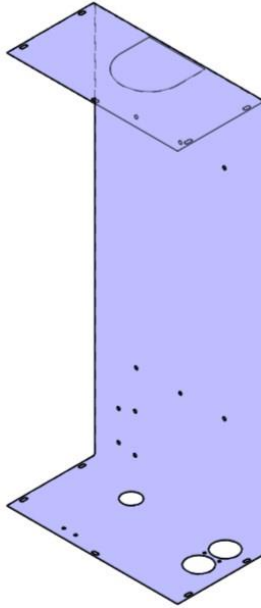

- 1mm thick M.S. sheet cut according to dwg.no. [VA2021-P005-00-0001](#)
- Above part cut on plasma cutter for that .dxf extension file is required
- Cut piece is a base sub assembly part of LPG based sanitary pad incinerator
- Bending a sheet properly according to above drawing.

10.2. Heating Chamber Assembly

10.2.a. Heating

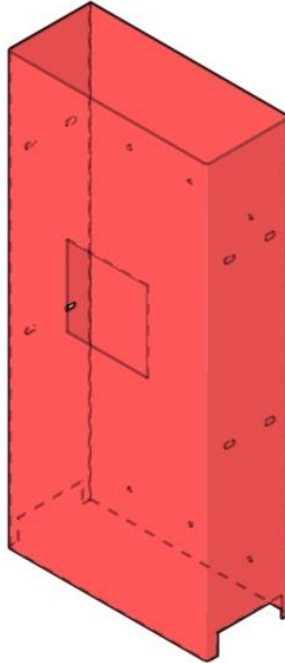

- 1.5 mm thick M.S. sheet cut according to dwg.no. [VA2021-P005-01-0001](#)
- Above part cut on plasma cutter for that .dxf extension file is required
- Cut piece fit on back panel in appropriate way.
- Bending a sheet properly according to above drawing.
- Welding properly a edge of heating chamber.

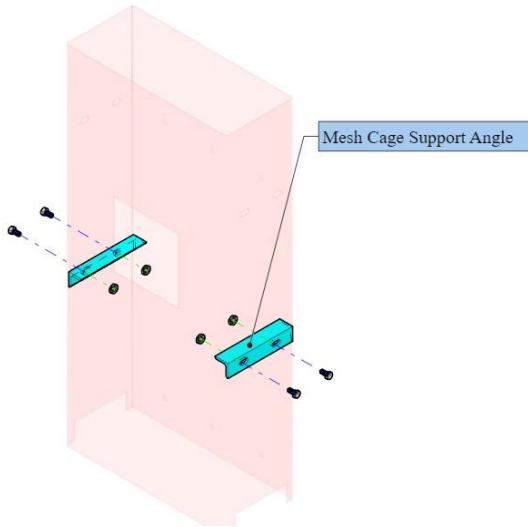

10.2.b. Mesh Cage Support Angle

- Support Angle made in Angle iron 20*20*3 mm.
- Cut & slot it according to dwg.no. [VA2021-P005-01-0002](#)

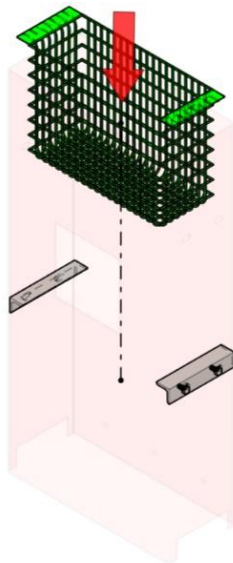

10.2.c. Inserting a Mesh Cage

- Insert a Mesh cage in heating chamber
- Rest on support angle

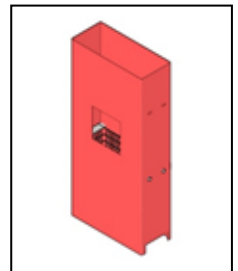

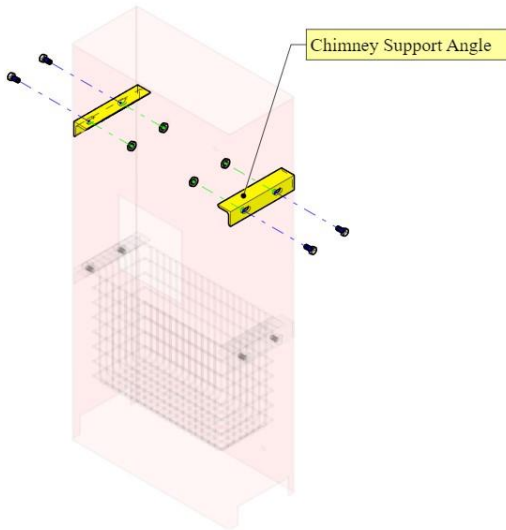

10.2.d. Chimney Support Angle

- Support Angle made in Angle iron 20*20*3 mm.
- Cut & slot it according to dwg.no. [VA2021-P005-01-0002](#)

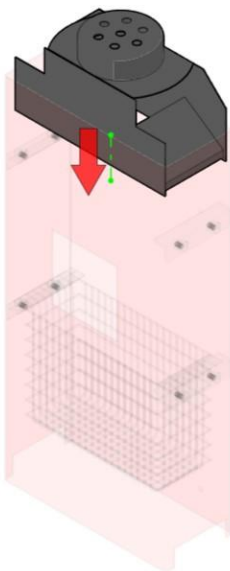

10.2.e. Chimney

- Insert a Chimney in heating chamber
- Rest on support

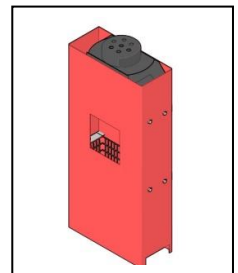

10.2.f. Passage Duct

- Weld a Passage Duct on heating chamber at colinear with silt.
- Heating chamber sub-assembly completed

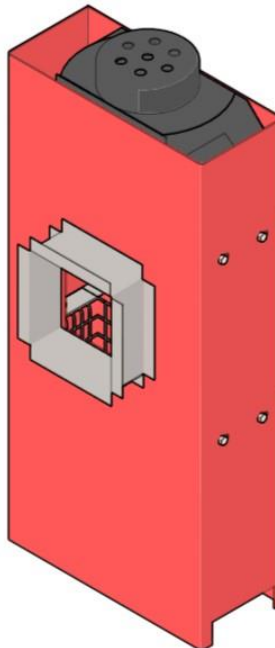
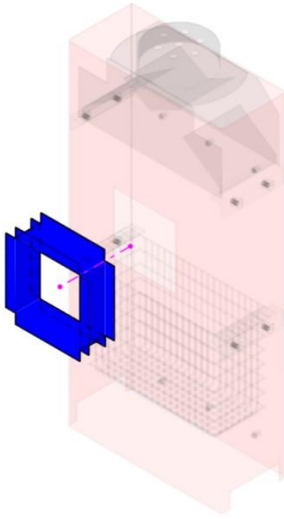

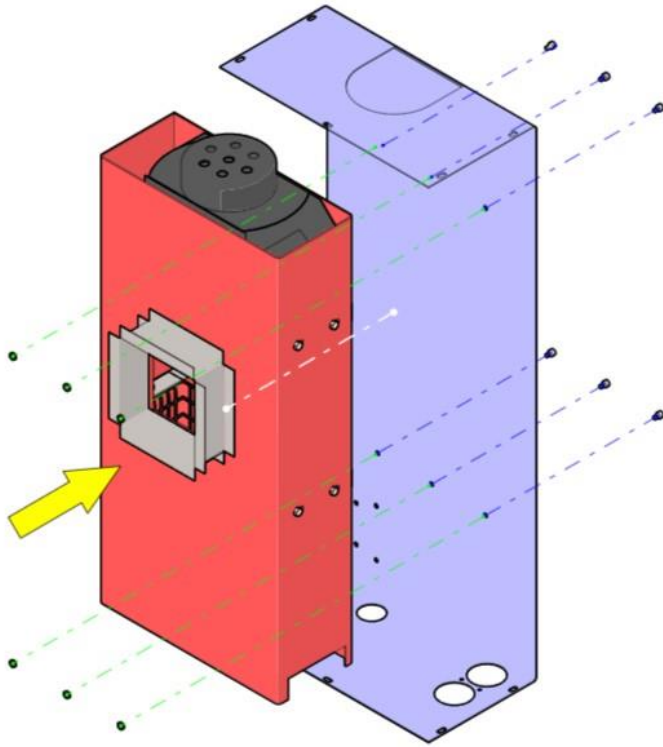

Heating chamber sub-assembly & Back Panel assembled together by matching appropriate holes & joined with fasteners.

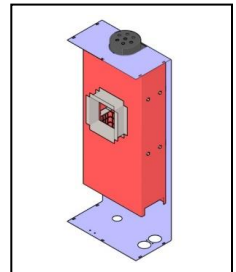

10.3. Regulated gas geyser system

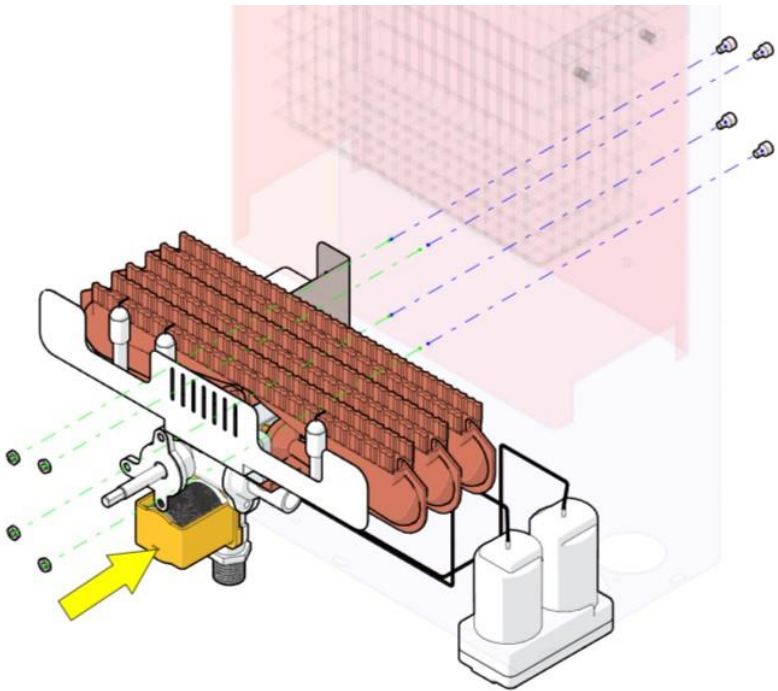

Regulated gas geyser system consists of Burner & Servo Motor Assembly.

- **Burner Assembly**
 - Gas Geyser Burner (H Shape)
 - Copper valve
 - S.V. valve
 - Battery Pack
 - Senser box
 - Gas igniters

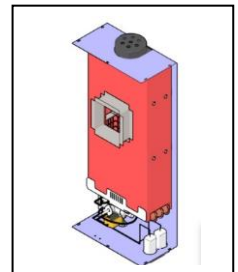

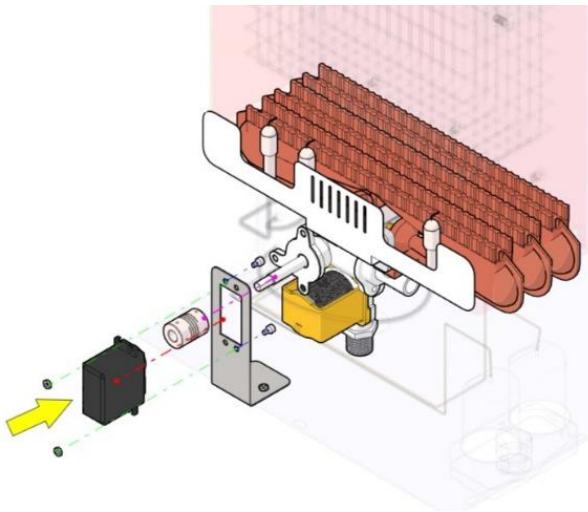
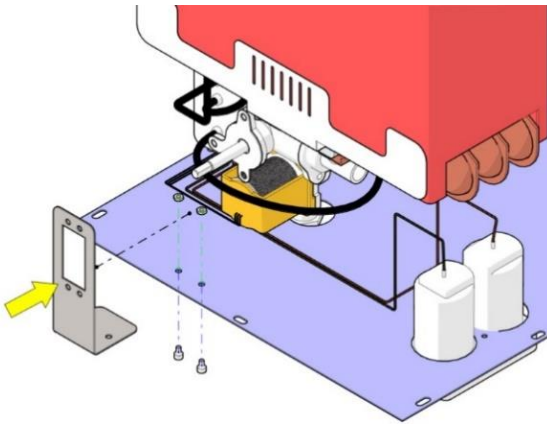

Servo Motor Assembly

- MG945, 5v servo motor is mount on stand [VA2021-P005-02-0002-1002-1](#) & it is colinear with copper valve.
- Servo motor & copper valve joined together with

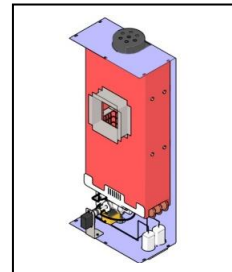

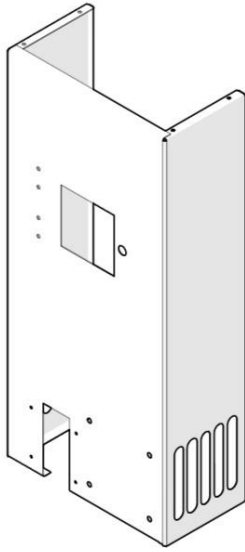

- 1mm thick M.S. sheet cut according to dwg.no. [VA2021-P005-04-0000](#)
- Above part cut on plasma cutter for that .dxf extension file is required
- Cut piece is a cover of LPG based sanitary pad incinerator
- Bending a sheet properly according to above drawing.

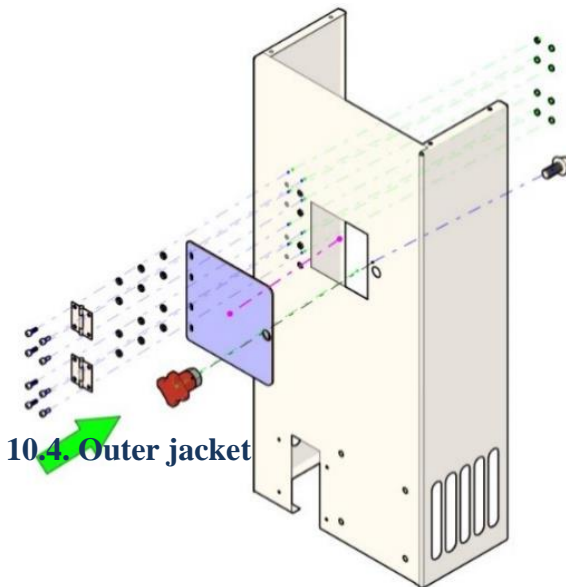

10.4. Outer jacket

- 2.5mm thick M.S. door plate & 20*20*3 square tube cut according to dwg.no. [VA2021-P005-04-0000](#)
- Door assemble with hinges, knob & fasteners

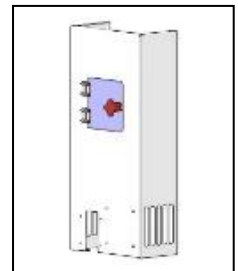

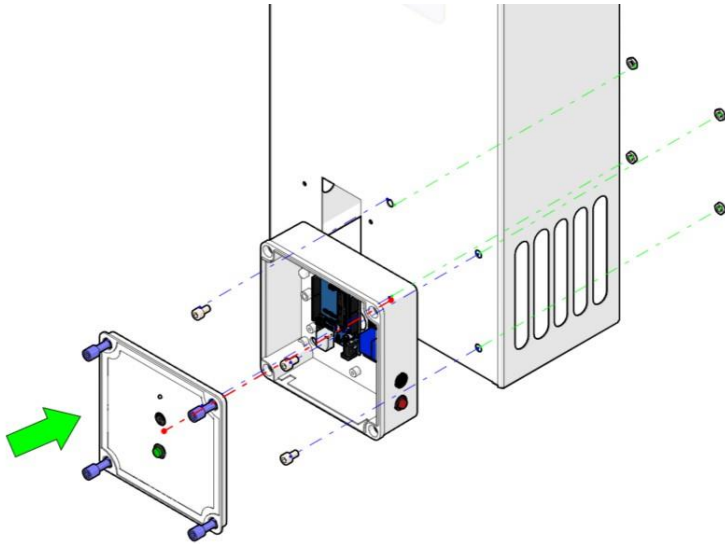

Panel box & wire fittings:

Panel box assembly contains,

- Arduino Uno
- 2 Channel Relay
- Buzzer
- LED
- Push Buttons
- Power Jack Male-Female
- Connecting wires

Wire fittings: [Schematic wire diagram](#)

- Connection is doing as per above wire diagram.

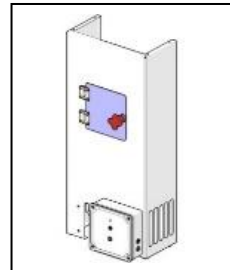

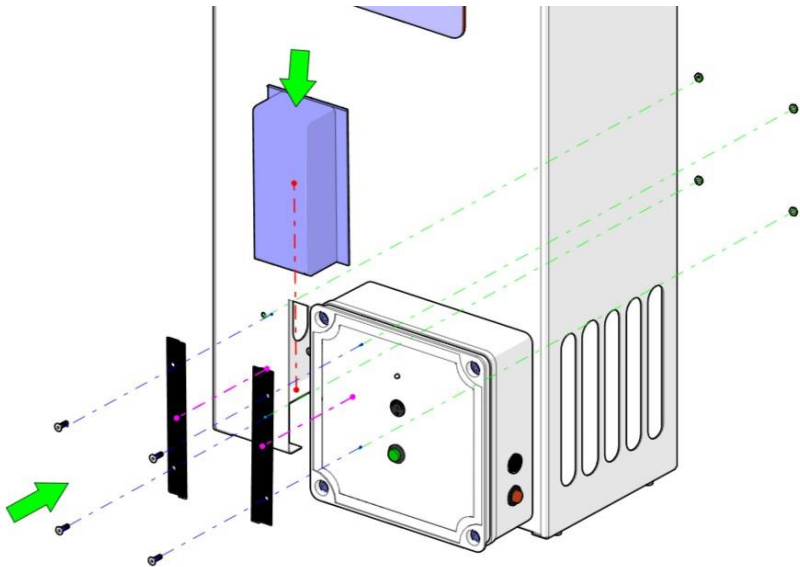

Servo MG945 Motor having enclosure for safety, it is attached on outer jacket. It contains,

- Servo Motor Casing- [VA2021-P005-04-0002-1005-01](#)
- Servo Motor Casing Slider- [VA2021-P005-04-0002-1005-02](#)
- Both are made by 3D printing, it is required. stl format file.

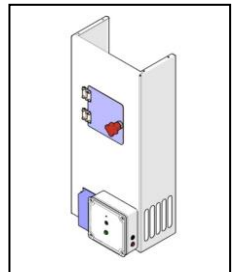

10.5. Complete Assembly

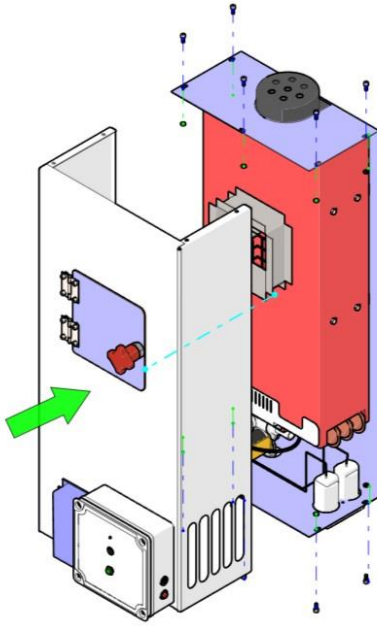

- LPG based sanitary pad incinerator having following sub-assemblies are Back panel, Heating chamber, Regulated gas geyser system, Outer jacket

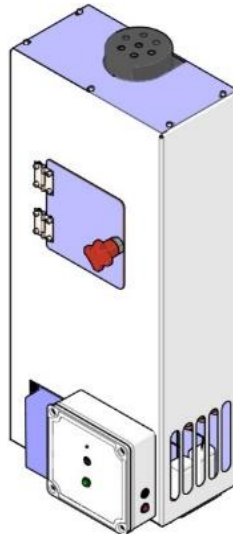

11. Commissioning of system

- Make a Bending properly for fabrication of sheet metal parts
- Make a welding properly for fabrication of Heating chamber & passage duct
- Make holes on sheet properly at specified positions.
- Wiring as shown in the block diagram of electronics components connections must be proper to short circuit & mis functioning.
- Door should be leak proof.
- Use glass wool as an insulating material.

12. Maintenance of system

- Check electrical supply & Battery condition for proper functioning of geyser.
- Check the Battery condition after three months of use (or as recommended by the Battery manufacturer)
- Disconnect the power supply & clean up the cabinet properly once in a month.

13. Disclaimer

The content in this DIY manual is the developed by Vigyan Ashram. All instructions are merely for educational purpose and to create a sharable open-source D-I-Y document.

While the information in this document has been verified to the best of our abilities, we cannot guarantee the performance. All the observation and data are taken from various experiments on system at Vigyan Ashram.

We reserve the right to change the design. Please contact our website or our expert team for any clarification.