



**VIGYAN  
ASHRAM**

# **Do-It- Yourself Manual**

## **GRAIN DISINFECTION UNIT**



**Supported by:**

**EAT•N**

*Powering Business Worldwide*

**DS DASSAULT  
SYSTEMES**

— La Fondation —

# INDEX

1. Introduction
2. Purpose of Project
3. Safety Instructions
4. Product Description
5. Features
6. Parts for make
7. Parts for purchase
8. Tools Required
9. How it Works? – Grain Disinfection Unit
10. Process of Assembly
11. Commissioning of System
12. Maintenance of System
13. Disclaimer

## 1. Introduction

Vigyan Ashram has designed & developed a Grain Disinfection Unit for Government Warehouse, Kirana Stores, and small Farmers & Households. Users of the manual will be able to build their own Grain Disinfection Unit using this manual. All the Bills of Materials (BOM) and dimensions of the systems are given in the design. We have provided design files drawn using Solidworks along with this manual. Users are suggested to read the manual carefully along with the site conditions before the fabrication of the unit.

Please watch following video carefully:

- [https://www.youtube.com/watch?v=j5EQeBa\\_6PI](https://www.youtube.com/watch?v=j5EQeBa_6PI)

## 2. Purpose of Manual

- To share the standardized design of Grain Disinfection Unit suitable for Government Warehouse, Kirana Stores, small Farmers & Households.
- Design to be made available online for local fabricators to build Grain Disinfection Unit for their customers.

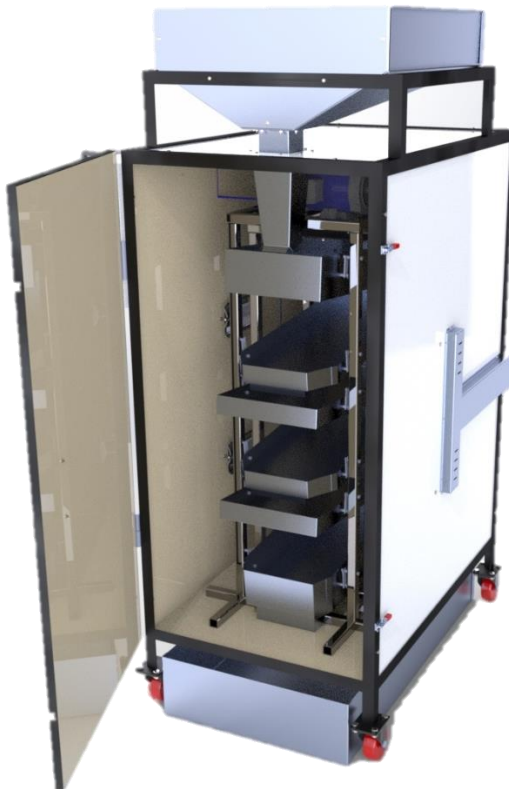

### 3. Safety Instructions

During fabrication of the system we should use safety equipment such as hand gloves, shoes and glasses.



(And as appropriate)

## 4. Product Description

The Grain Disinfection Unit consist of outer insulation chamber, conveyer tray system, on top hopper and collection tray at bottom and Air heating & circulation system.

Outer Insulation chamber made up from 12mm thick plywood.

The detail view and bill of materials are given below:

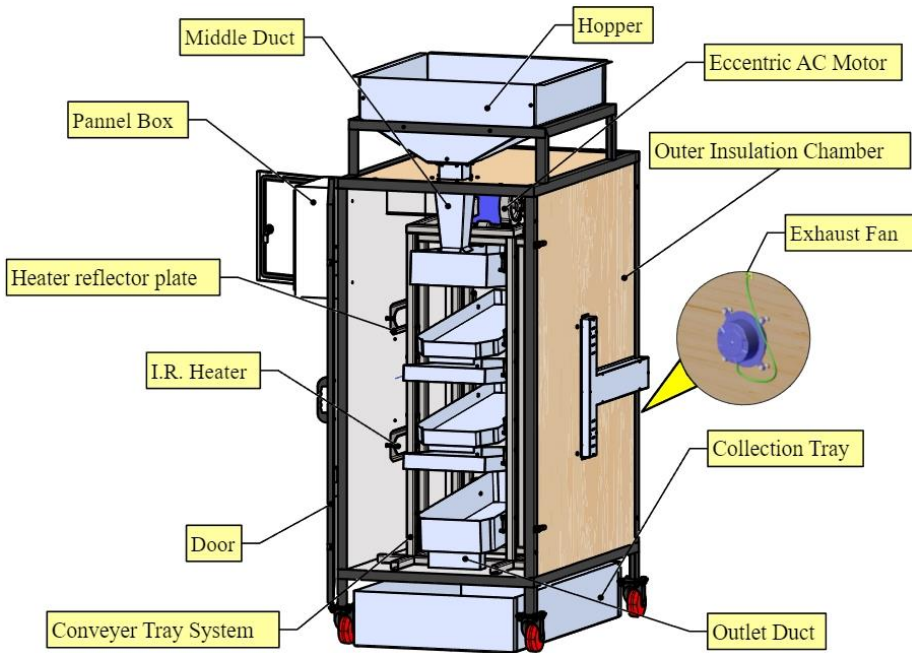

[Grain Disinfection Unit BOM](#)

[GDU Library BOM](#)

## 5. Features

- Feed Rate @ 40 to 45 Kg/hr.
- Modular System
- Easy to fabricate
- Easy to operate
- Easy to maintenance
- High Grain Disinfection rate
- Hot air is conveyed to each grain in the right proportion.
- Reduces the moisture content of the grain (up to 1 to 2%)
- Treatment cost is cheap @ 40 to 70 paise/kg.

## 6. Parts for make

No.	Part Name	Dwg. Ref (pdf)
1	Cabinet Structure Frame	<a href="#">VA2021-P004-00-0001</a>
		<a href="#">VA2021-P004-00-0001 (2)</a>
2	Back side Plywood	<a href="#">VA2021-P004-00-0001-1002/1</a>
3	RHS side Plywood	<a href="#">VA2021-P004-00-0001-1002/2</a>
4	LHS side Plywood	<a href="#">VA2021-P004-00-0001-1002/3</a>
5	Top side Plywood	<a href="#">VA2021-P004-00-0001-1002/4</a>
6	Bottom side Plywood	<a href="#">VA2021-P004-00-0001-1002/5</a>
7	Cabinet Structure Door Frame	<a href="#">VA2021-P004-00-0002</a>
8	Door Plywood	<a href="#">VA2021-P004-00-0002-1003/1</a>
9	Hopper	<a href="#">VA2021-P004-00-0003</a>
		<a href="#">VA2021-P004-00-0003 (2)</a>
10	Front Cover of Hopper	<a href="#">VA2021-P004-00-0003-1004/1</a>
11	Middle Duct	<a href="#">VA2021-P004-00-0004</a>
12	Middle Duct 2	<a href="#">VA2021-P004-00-0005</a>
13	Outlet Duct	<a href="#">VA2021-P004-00-0006</a>
14	Tray No.4	<a href="#">VA2021-P004-00-0007</a>
15	Conveyer Tray System	<a href="#">VA2021-P004-01-0000</a>
16	Outer Frame	<a href="#">VA2021-P004-01-0001</a>
		<a href="#">VA2021-P004-01-0001 (2)</a>
17	Inner Frame	<a href="#">VA2021-P004-01-0002</a>
		<a href="#">VA2021-P004-01-0002 (2)</a>



18	Tray No.1	<a href="#"><u>VA2021-P004-01-0003</u></a>
19	Tray No.2,3,4,5	<a href="#"><u>VA2021-P004-01-0004</u></a>
20	Tray No.3,6	<a href="#"><u>VA2021-P004-01-0005</u></a>
21	Single head nylon bush(12mm)	<a href="#"><u>VA2021-P004-01-0006</u></a>
22	Single head nylon bush(15mm)	<a href="#"><u>VA2021-P004-01-0007</u></a>
23	Single head nylon bush(34mm)	<a href="#"><u>VA2021-P004-01-0008</u></a>
24	Single head nylon bush(37mm)	<a href="#"><u>VA2021-P004-01-0009</u></a>
25	Lead Pin (20mm)	<a href="#"><u>VA2021-P004-01-0010</u></a>
26	Lead Pin (25mm)	<a href="#"><u>VA2021-P004-01-0011</u></a>
27	Lead Pin (46mm)	<a href="#"><u>VA2021-P004-01-0012</u></a>
28	Lead Pin (55mm)	<a href="#"><u>VA2021-P004-01-0013</u></a>
29	Lead Pin (42mm)	<a href="#"><u>VA2021-P004-01-0014</u></a>
30	Cotter Pin	<a href="#"><u>VA2021-P004-01-0015</u></a>
31	Inner & Outer cage link	<a href="#"><u>VA2021-P004-01-0016</u></a>
32	Outer cage link	<a href="#"><u>VA2021-P004-01-0017</u></a>
33	Reflecting plates	<a href="#"><u>VA2021-P004-02-0002</u></a>
34	RHS Wire Duct	<a href="#"><u>VA2021-P004-03-0005</u></a>
35	RHS Wire Duct Plate	<a href="#"><u>VA2021-P004-03-0006</u></a>
36	Back Wire Duct	<a href="#"><u>VA2021-P004-03-0007</u></a>
37	LHS Wire Duct	<a href="#"><u>VA2021-P004-03-0008</u></a>
38	LHS Wire Duct Plate	<a href="#"><u>VA2021-P004-03-0009</u></a>
39	LHS Wire Duct 2	<a href="#"><u>VA2021-P004-03-0010</u></a>

## 7. Parts for purchase

No.	Part Name	Specification	Qty.
1.	Castor Wheel	Aluminum Narrow Court Caster (2"x1")	4
2.	Eccentric Motor	¼ hp AC Induction	1
3.	Electric Panel Box	300mm*200mm*400mm (l*b*h)	1
4.	Ceramic Heaters	IR- 500W	4
5.	Exhaust Fans	Air flow rate: 510 cmh , Speed: 1350 RPM , Sweep size: 230 mm	1
6.	MCB	Single pole, 16A	3
7.	Rail	Aluminum	1
8.	Rail Terminal Block	6mm	6
9.	2 Way Connector	Ceramic	4
10.	Ceramic Bush	4 Sq.mm dia	8
11.	Wire Tie Clip(8mm)	8mm, Plastic	18
12.	Wire Tie Clip	6mm, Plastic	7
13.	Nail Cable Clip (6.4 mm DÍA)	Plastic	7
14.	Toggle clamp type latch	Horizontal	2
15.	Handle	HDPE/Steel	1

## 8. Tools required

Hand Grinder

Drill Machine

Power cutter

Welding  
Machine

Scale

Measuring  
Tape

Allen Key Set

Marker

Paint Brush

Vernier  
Caliper

## 9. How it works? : Grain Disinfection Unit

Food grains are essential dietary components that consist of various nutrients (including vitamins, minerals, protein, and carbohydrates) required for a healthy life and growth of the human body. Rice, Wheat, Maize, millets, and sorghum are some of the major grown and consuming grains in day-to-day diet. These grains are consumed mostly on a regular basis while the cultivation periods or seasons are fixed. The food grains are stored after harvesting for consumption up to the next harvesting cycle of the crops.

The goal of the commercial farming sector is to get as many crops or produce as possible in the shortest possible time. The trend has been growing for centuries. The rabbi cultivates the land immediately after the wheat is harvested and, it is necessary to plan the next crop with other preparations. But one task always remains the same is the proper storage of harvested grains. Previously every farmer used 'Khali' as the place for harvesting, threshing and turning of grain. Now it's time harvested by Machines; therefore, the drying is not separately done. Every time farmers faced some problems like cloudy weather, unseasonal rains.

The cumulative effect is that large-scale grain storage is impaired, as are grain pests. This problem is slightly different every year. Farmers are expected That this issue should be handled by the traders or the market committee

but the drying of the grains in a scientific manner and there was a huge loss of farmers without storage.

Every year in India normally 10-15% of the grain, about 30 million tons, are rotten in the godown. How much labor, fertilizer, medicine is calculated for growing about 1 ton (1000 kg) of grain? So, the size of the damage can be estimated. In addition, grain loss, adding the cost of transportation to this would increase the national loss many times over.

Considering the scientific method, the water content of grain for storage has been reduced by 6 to 8%. If so, the storage pest does not harm the grains (because its life cycle stops due to the absence of water). Also suitable in the dry environment after proper drying having to be stored in bags.

With all this in mind, Vigyan Ashram has developed a 'GRAIN DISINFECTION UNIT'. This machine is very useful for farmers, small traders, market committees etc. In this machine, by heating up to 55°C, this hot air is conveyed to each grain in the right proportion; that's why all-grain pests are dead.

This unit processes the grain at high temperatures i.e., reduces the moisture content of the grain (up to 1 to 2%) and makes the grain last longer. This device is very easy to use and maintain. The capacity of this device is 40 to 45 kg/hr, it can run on electricity.

The cost is around 40 to 70 paisa/kg. Wheat, sorghum, millet, maize, sorghum also process through this unit.

## 10. Process of Assembly

1. Insulation Chamber Assembly
  - a. Frame
  - b. Plywood walls
    - i. Back
    - ii. RHS & LHS
    - iii. Bottom
    - iv. Top
  - c. Castor Wheel & Toggle clamp type latch
  - d. Door Assembly
    - i. Door Frame
    - ii. Door Ply
2. Air Heating & circulation system
  - a. Heater reflector plates
  - b. Exhaust Fans
  - c. Heaters
3. Conveyer Tray system
  - a. Outer frame
  - b. Inner frame
  - c. Tray No.1
  - d. Tray No.2
  - e. Tray No.3
  - f. Tray No.4
  - g. Tray No.5
  - h. Eccentric AC Motor
4. Hopper & Ducts
5. Panel box & wire duct fittings

# 10.1 Insulation Chamber

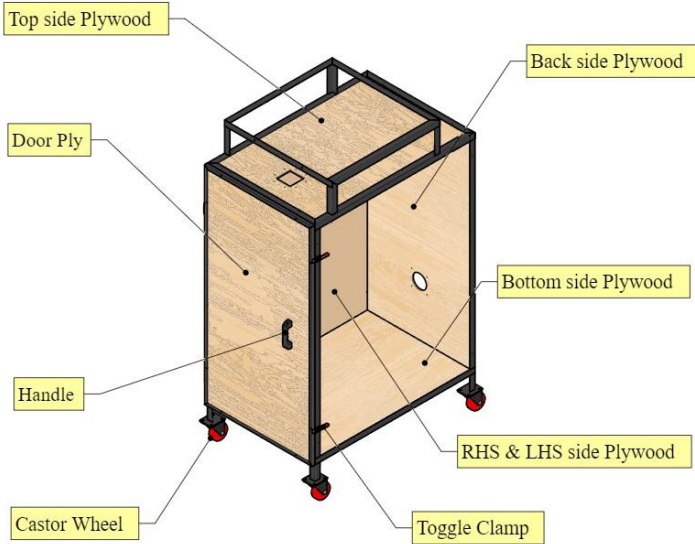

BOM ID	Description	Qty
1	Back side Plywood	1
2	Cabinet Structure Frame	28
3	Castor Wheel	12
4	Clamping Hook	2
5	Clamping Plate	2
7	Door Frame	4
6	Door Ply	1
8	Handle	2
9	Hexagon Nut (M5)	2
10	Hinge Male	2
11	Pan Head Screw (M5*35)	2
13	Pivote Base Plate	2
12	Pivote Pin	2
14	Plastic Handle	1
15	RHS & LHS side Plywood	2
16	Top side Plywood	1

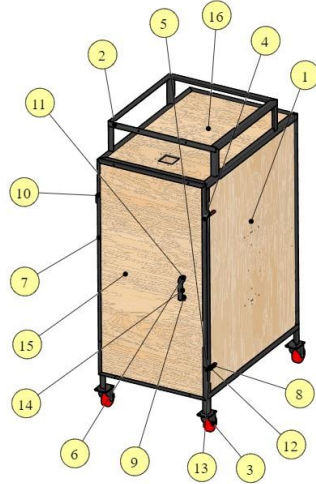

## 10.1.a Frame

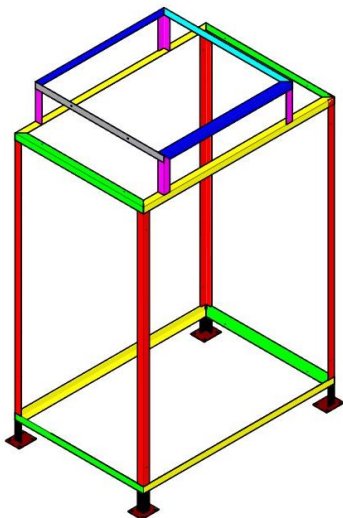

Angle Color	BOM ID
	1
	2
	3
	4
	5
	6
	7
	8

BOM ID	Description	Qty
1	Angle iron 35 X 35 X 5(Black 100mm)	4
2	Angle iron 35 X 35 X 5(Blue 750mm)	3
3	Angle iron 35 X 35 X 5(Green 750mm)	4
4	Angle iron 35 X 35 X 5(Pink 200mm)	4
5	Angle iron 35 X 35 X 5(Red 1433mm)	4
6	Angle iron 35 X 35 X 5(Yellow 1115mm)	4
7	Base Plate	4
8	Flat Plate 35*3 750mm	1

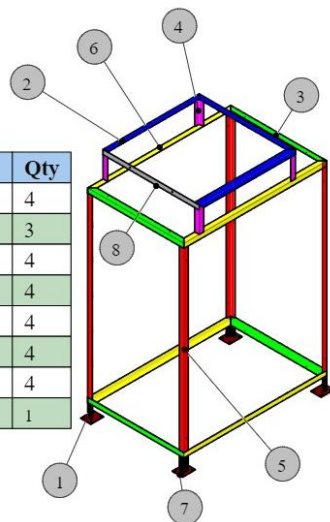



## 10.1.b Plywood walls

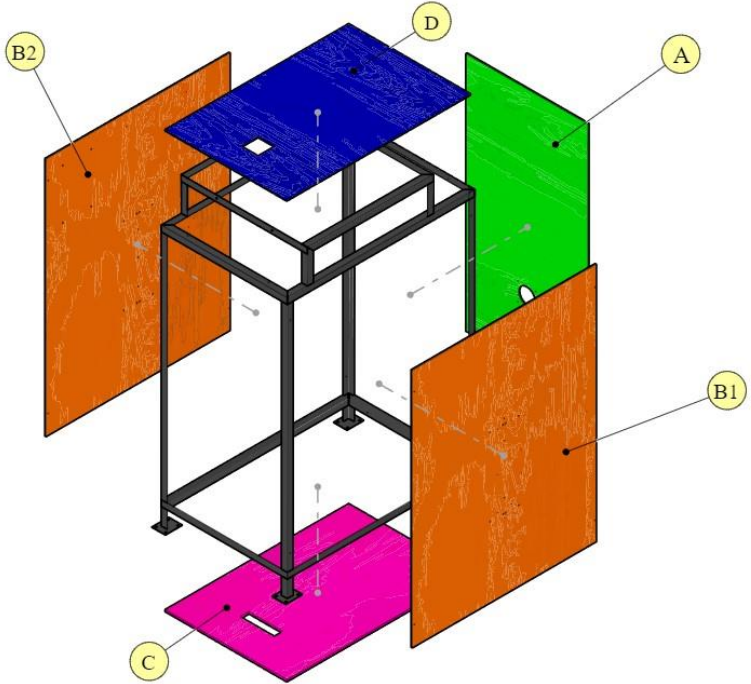

Code	Color	Plywood Name
A	Green	Back Wall
B1,B2	Orange	Side Wall (LHS,RHS)
C	Pink	Bottom Wall
D	Blue	Top Wall

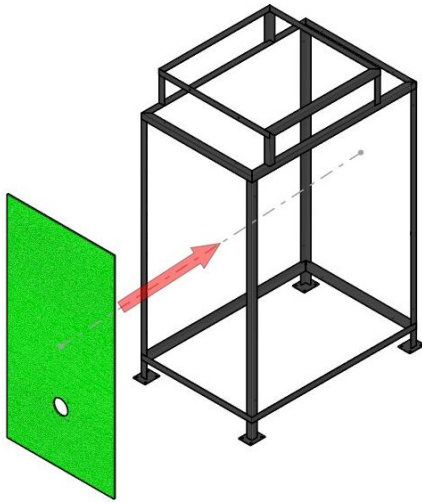

### A. Back Wall Sub-Assembly

- 12mm thick plywood cut according to dwg.no. [VA2021-P004-00-0001-1002/1](#)
- Cut piece fit into back of insulation chamber frame

### B1. Side Wall (LHS) Sub-Assembly

- 12mm thick plywood cut according to dwg.no. [VA2021-P004-00-0001-1002/2](#)
- Cut piece fit into right hand side of insulation chamber frame

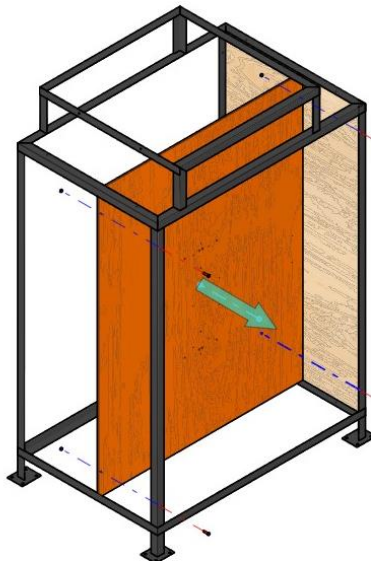

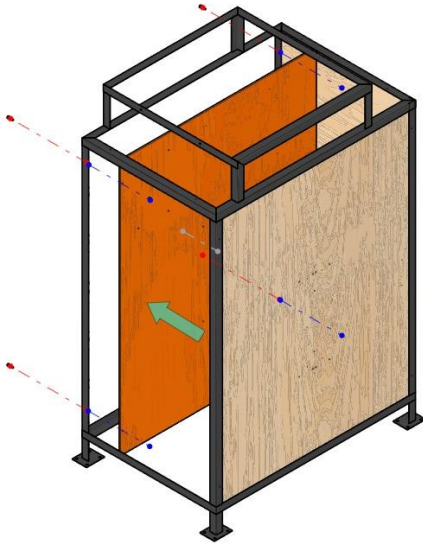

### **B2. Side Wall (RHS) Sub-Assembly**

- 12mm thick plywood cut according to dwg.no. [VA2021-P004-00-0001-1002/3](#)
- Cut piece fit into left hand side of insulation chamber frame

### **C. Bottom Wall Sub-Assembly**

- 12mm thick plywood cut according to dwg.no. [VA2021-P004-00-0001-1002/5](#)
- Cut piece fit into bottom side of insulation chamber frame

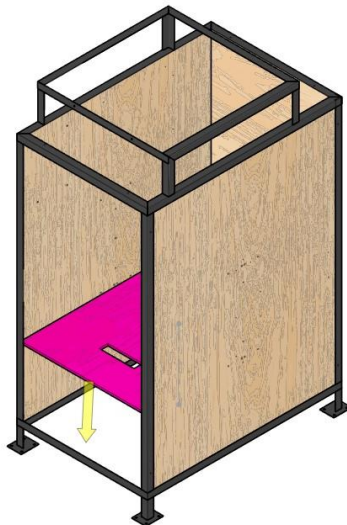

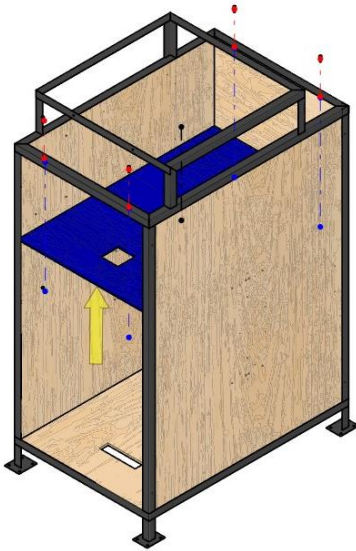

#### **D. Top Wall Sub-Assembly**

- 12mm thick plywood cut according to dwg.no. [VA2021-P004-00-0001-1002/4](#)
- Cut piece fit into top side of insulation chamber frame

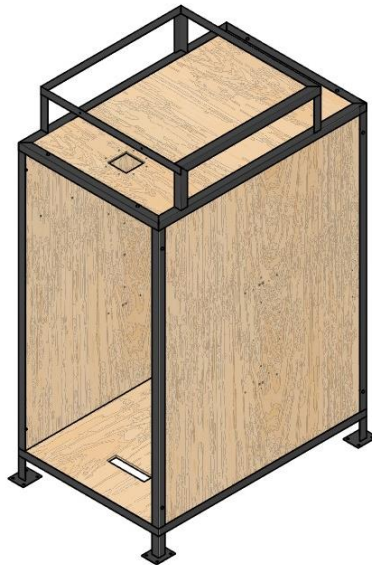

## 10.1.c Castor Wheel & Toggle clamp type latch

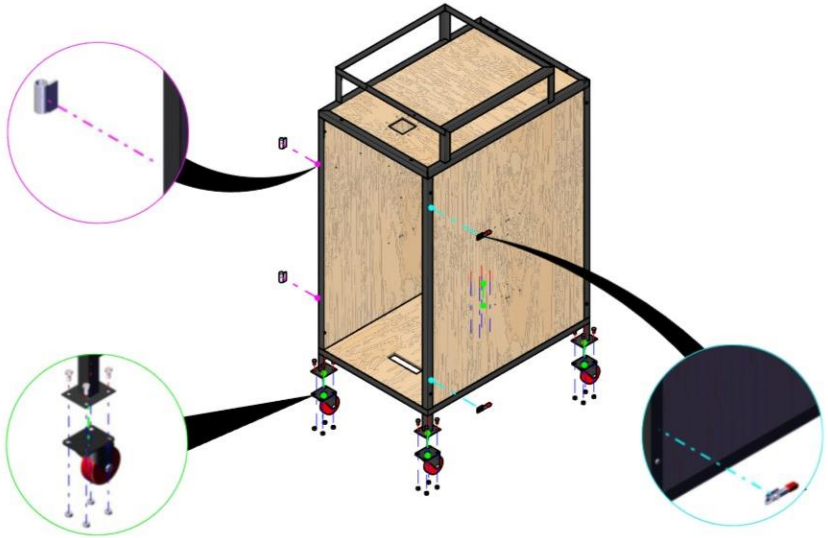

Insulation Chamber having three mountings are as follows,

1. Castor Wheel  
It is mount under base plate of insulation box frame
2. Horizontal Toggle clamp type latch  
It is mount on right hand side of insulation box frame.
3. Door female hinge is mount on left hand side of insulation box frame.

## 10.1.d Door Assembly

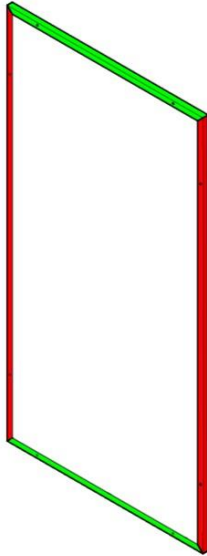

- Insulation Chamber door having door frame dwg.no. [VA2021-P004-00-0002](#)
- Door frame made in Angle iron 20\*20\*3 mm.

BOM ID	Description	Qty
1	Angle iron 20 X 20 X 3(Green 750mm)	1
2	Angle iron 20 X 20 X 3(Green 750mm)	1
3	Angle iron 20 X 20 X 3(Red 1450mm)	1
4	Angle iron 20 X 20 X 3(Red 1450mm)	1

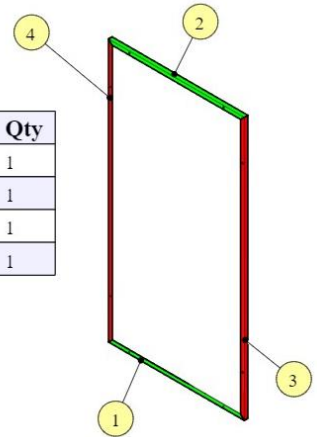

Door Assembly having 12mm thick plywood surface. It is cut according to dwg.no. [VA2021-P004-00-0002-1003/1](#)

Insulation Chamber having three mountings are as follows,

1. Horizontal Toggle clamp type latch Hook at right side of door frame
2. Handle on front surface of plywood
3. Door female hinge is mount on left hand side of door frame.

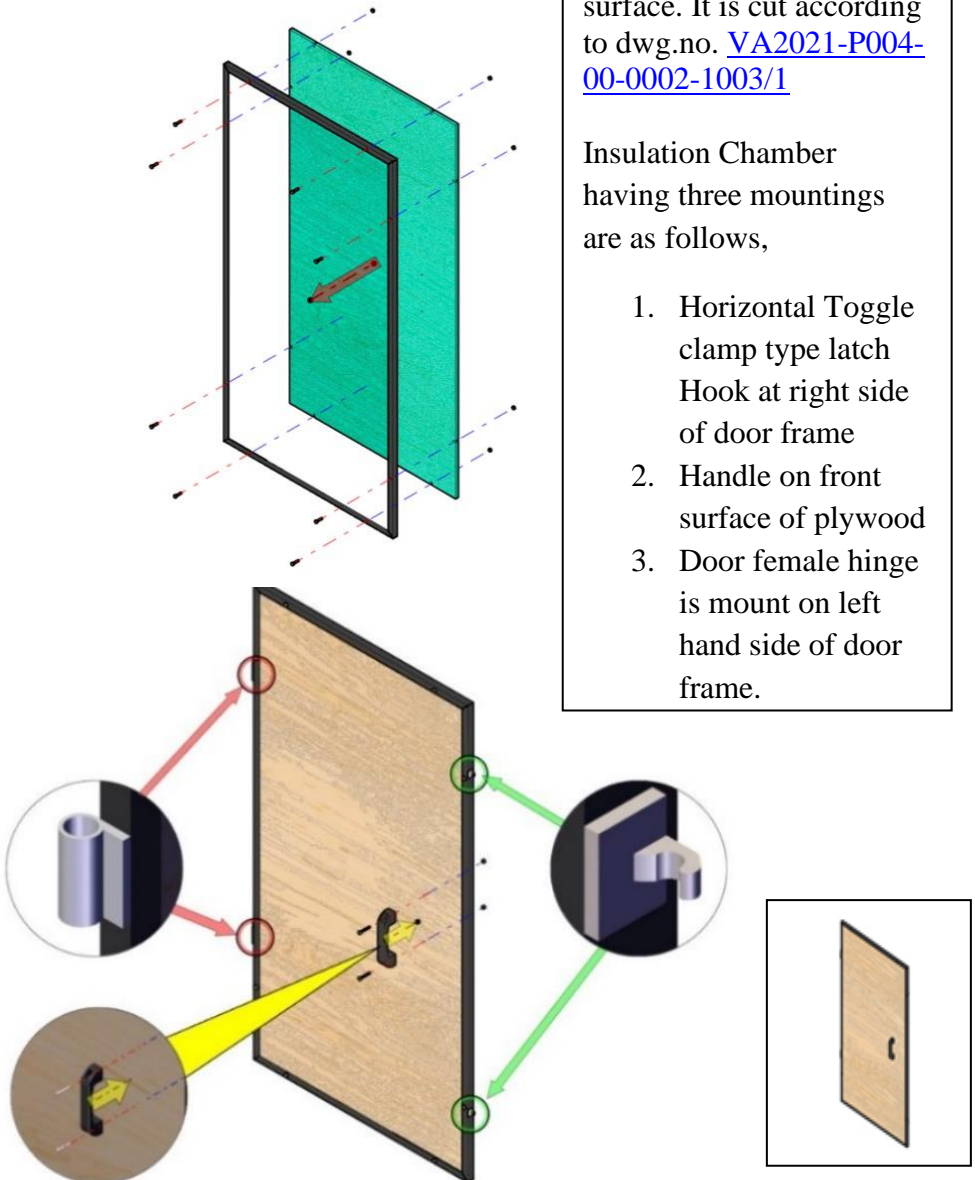

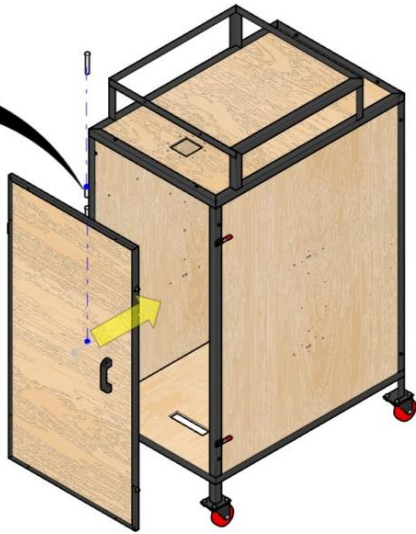

Insulation Chamber made by two sub-assemblies are,

- Insulation Chamber Frame
- Door Assembly





## 10.2. Air Heating & circulation

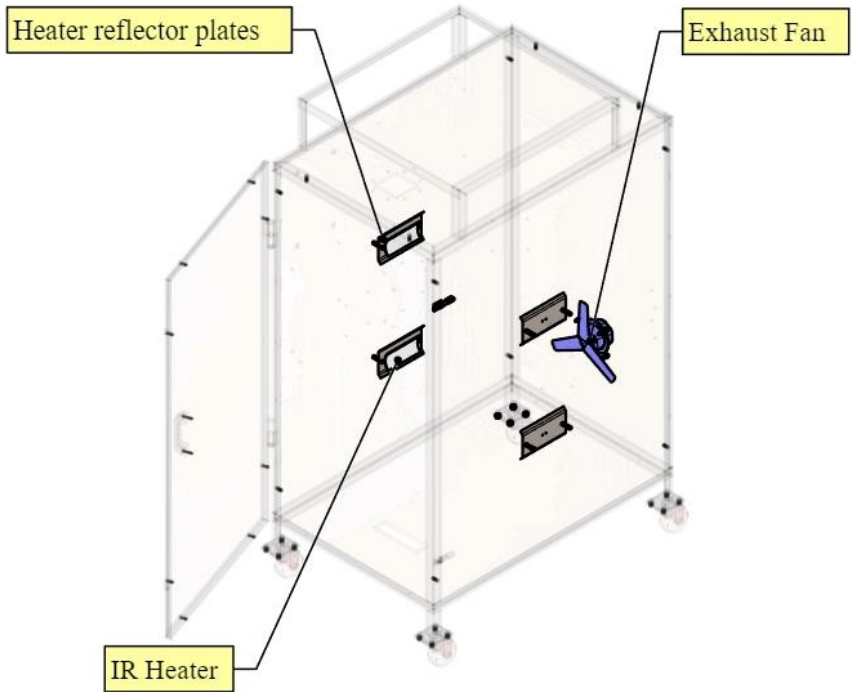

Grain disinfection unit consist of Air Heating & circulation system. System having following sub-assemblies & mountings,

1. Heater reflector plates

Ref. No. [VA2021-P004-02-0002](#)

2. Exhaust Fans
3. Heater

# 10.2.a. Heater reflector plate

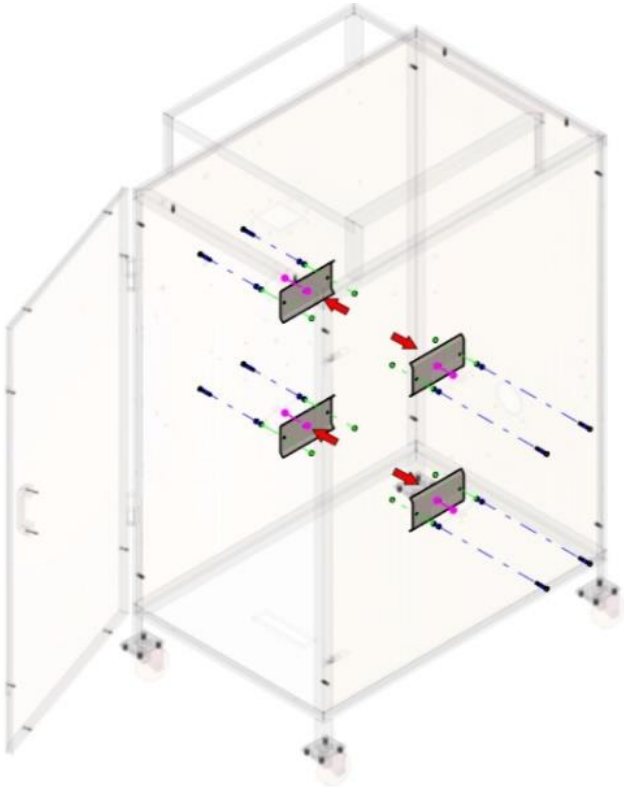
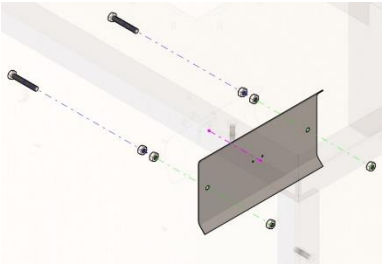
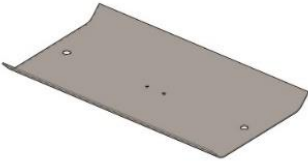

## 10.2. b. Exhaust Fan

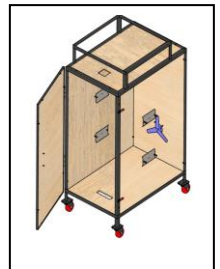
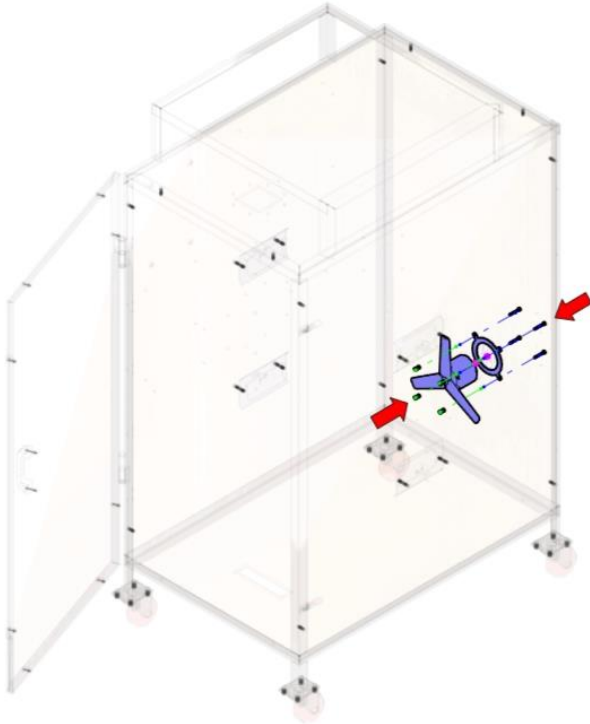
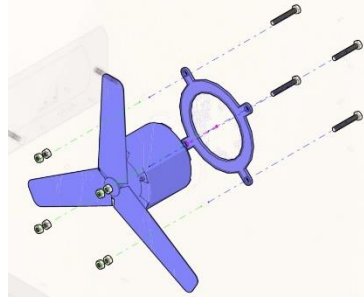
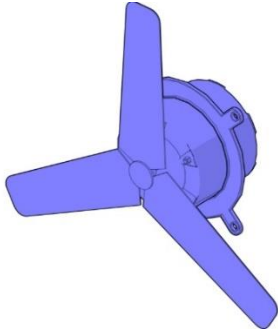

# 10.2. c. Heaters

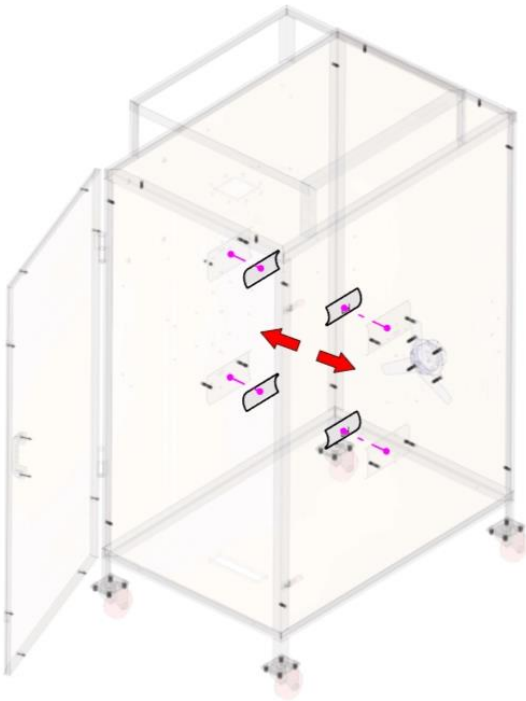
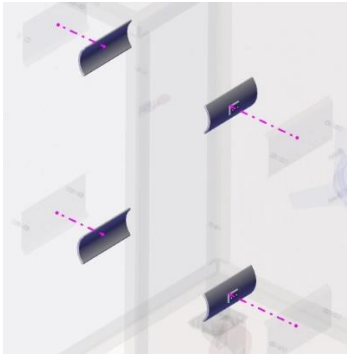

### 10.3. Conveyer Tray system

BOM ID	Description	Qty
1	Cotter Pin	112
2	Eccentric AC MOTOR	3
3	Inner Cage	12
4	Inner+Outer cage link	4
5	Moter mounting plate	2
6	Outer Cage	20
7	Outer cage link	24
8	Pin	8
9	Pin (L= 20mm)	16
10	Pin (L= 25mm)	8
11	Pin (L= 46mm)	16
12	Pin (L= 55mm)	8
13	Single head Nylon Bush	5
14	Single head Nylon Bush (L=12mm)	16
15	Single head Nylon Bush (L=15mm)	8
16	Single head Nylon Bush (L=35mm)	16
17	Single head Nylon Bush (L=42mm)	8 </td
18	Tray	6
19	Hex flange bolt(IS15582 M5*25*25)	4
20	Hexagon fit bolt(IS3640 M8*45*14.5)	4
21	Hexagon flange nut(IS15581 M8 )	8

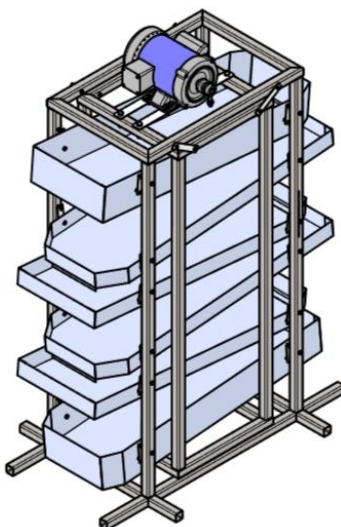
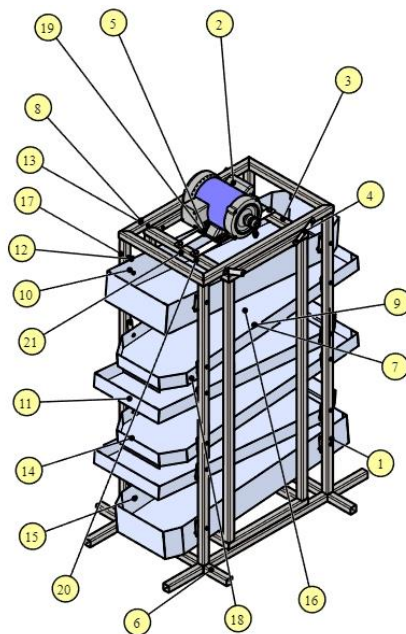

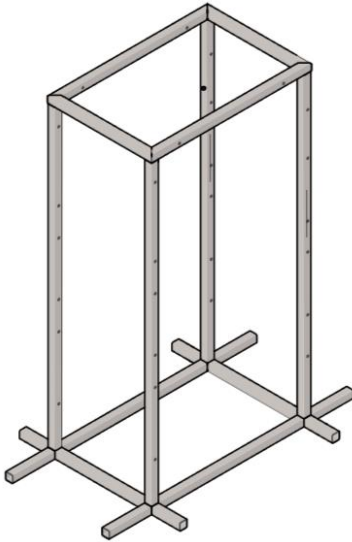

### Outer frame:

- Square tube cut according to dwg.no.
  - [VA2021-P004-01-0001](#)
  - [VA2021-P004-01-0001 \(2\)](#)
- Cut piece required drilling & welding operation.

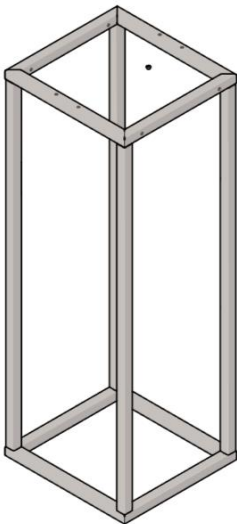

### Inner frame:

- Square tube cut according to dwg.no.
  - [VA2021-P004-01-0002](#)
  - [VA2021-P004-01-0002 \(2\)](#)
- Cut piece required drilling & welding operation.

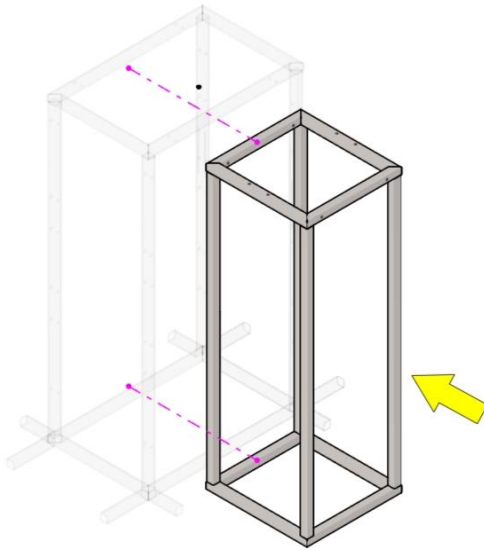

Inner frame is coincided with Outer frame and it is joined together by using

1. Cage link
2. Single head nylon bush
3. Pin
4. Cotter Pin

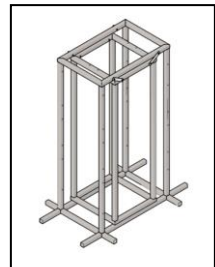
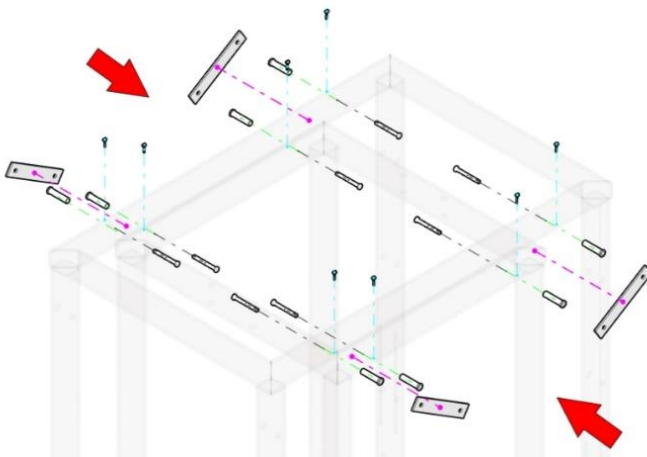

**Tray No.1**

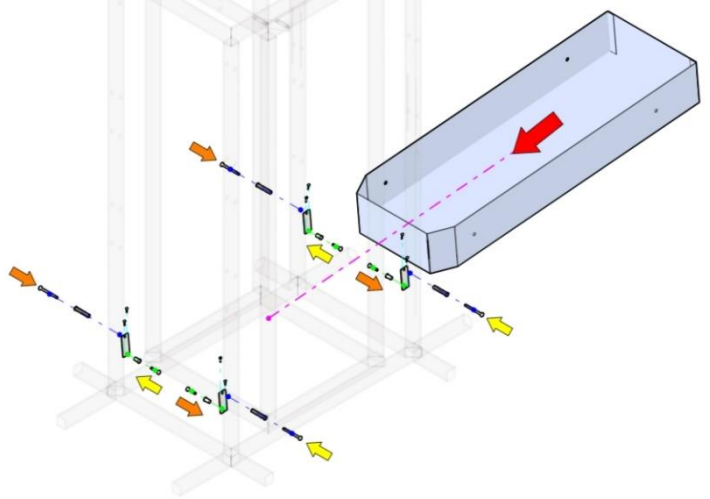

**Tray No.2**

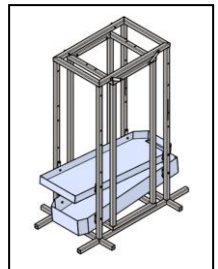
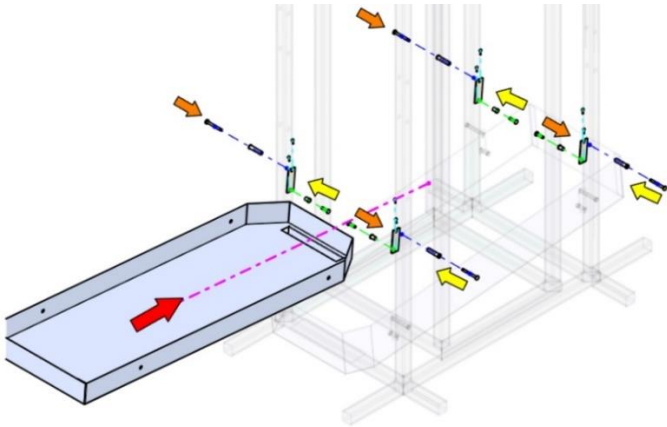



**Tray No.3**

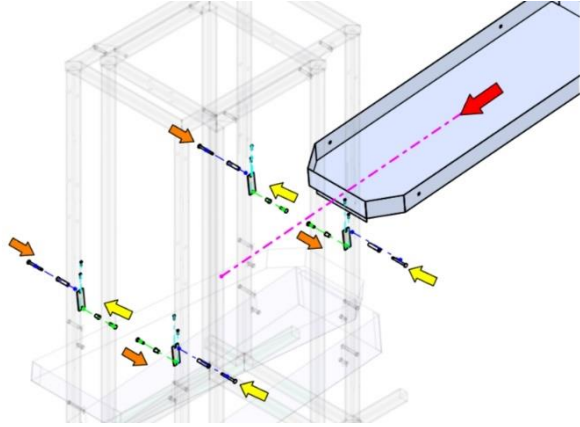

**Tray No.4**

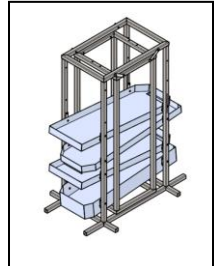
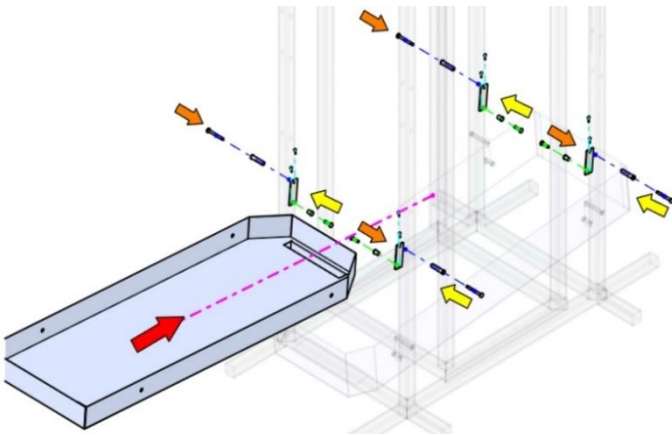

**Tray No.5**

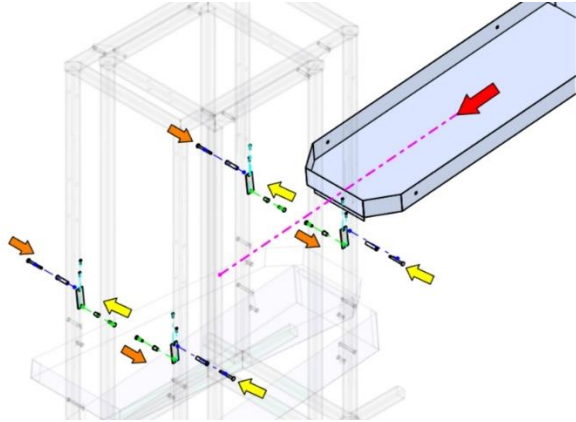

**Tray No.6**

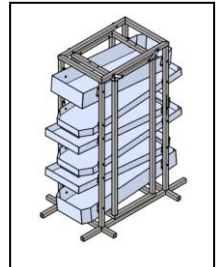
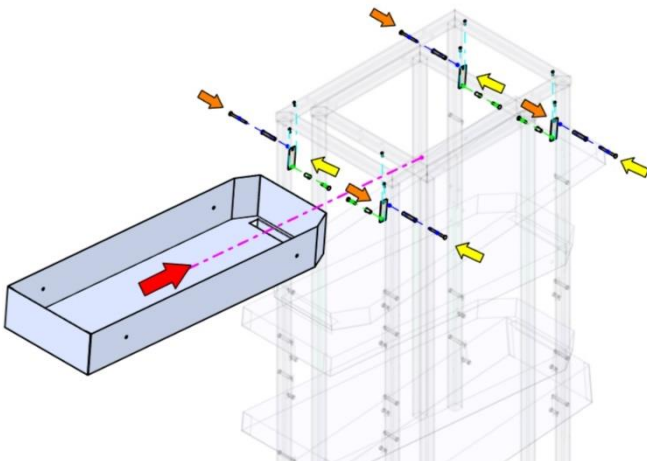

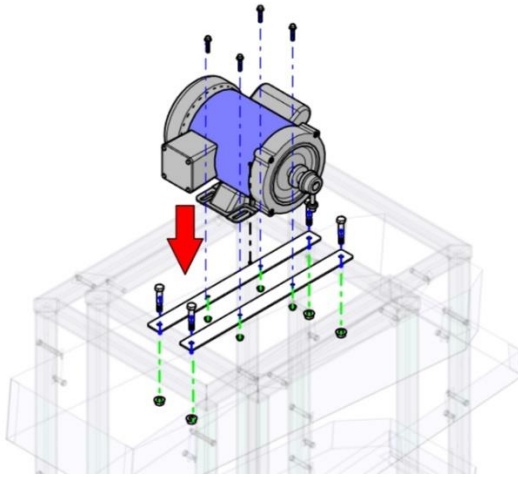

**Eccentric AC Motor:**

Eccentric AC Motor  
Joined on inner cage  
structure by using  
support plates &  
appropriate fixtures

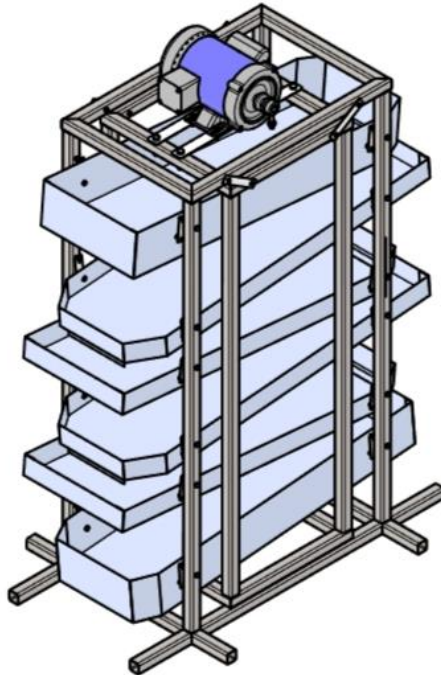

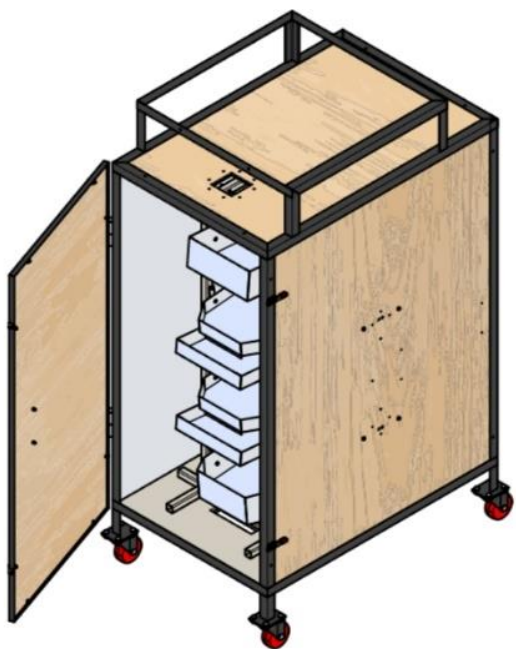
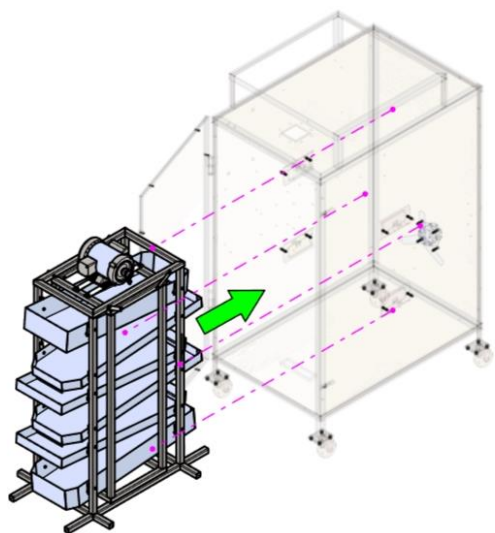

# 10.4. Hopper & Ducts

**Middle**  
**Duct2:**[Dwg.no. VA2021-P004-00-0005](#)

**Hopper & Front**  
**Plate:**[VA2021-P004-00-0003](#),  
[VA2021-P004-00-0003 \(2\)](#),  
[VA2021-P004-00-0003-1004/1](#)

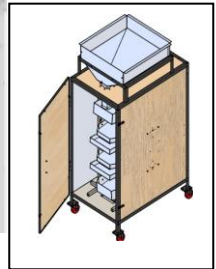
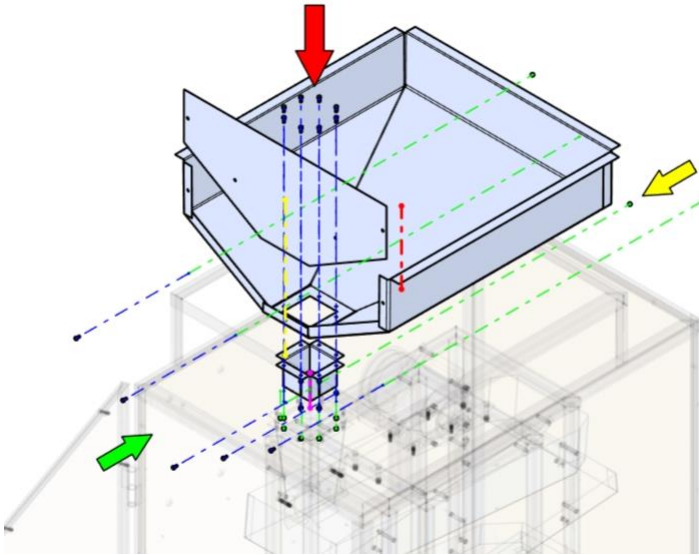
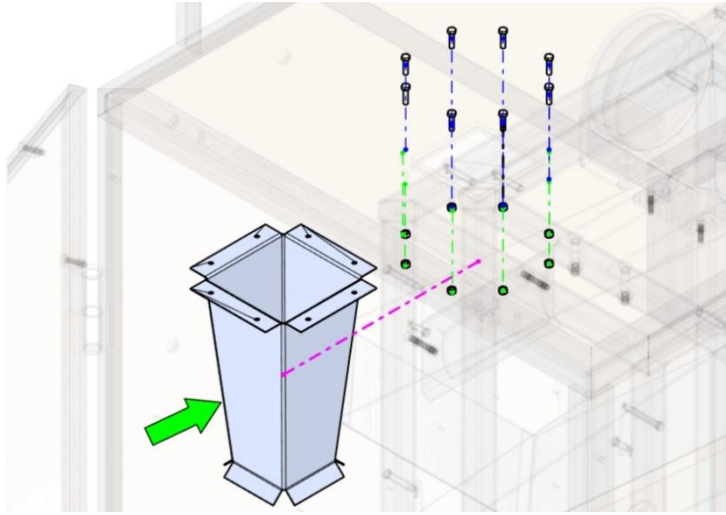

# 10.4. 5. Panel box & Wire duct fittings

**Panel Box:**

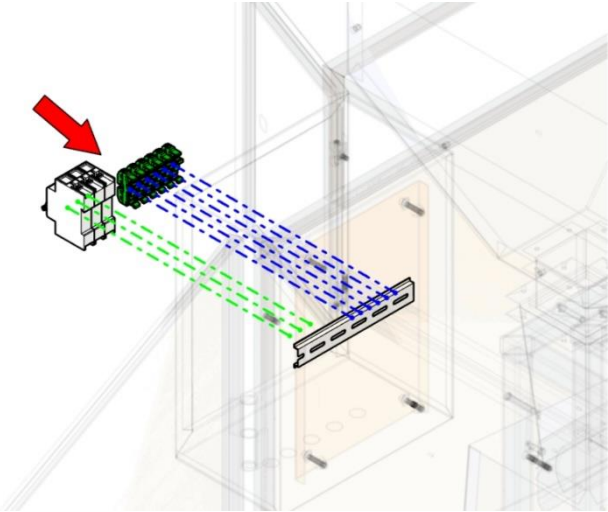
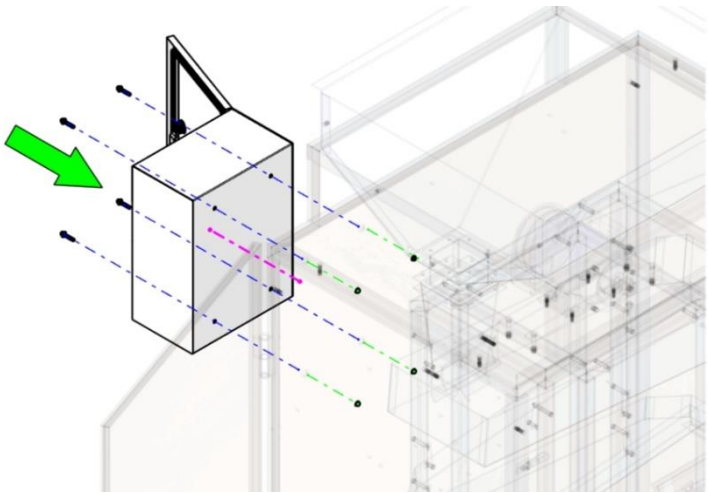

**MCB &  
Rail  
Terminal  
Block  
Assembly**

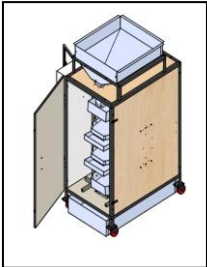

**Wire fitting of  
eccentric  
motor,  
Heaters &  
Exhaust Fan**

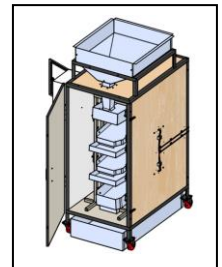
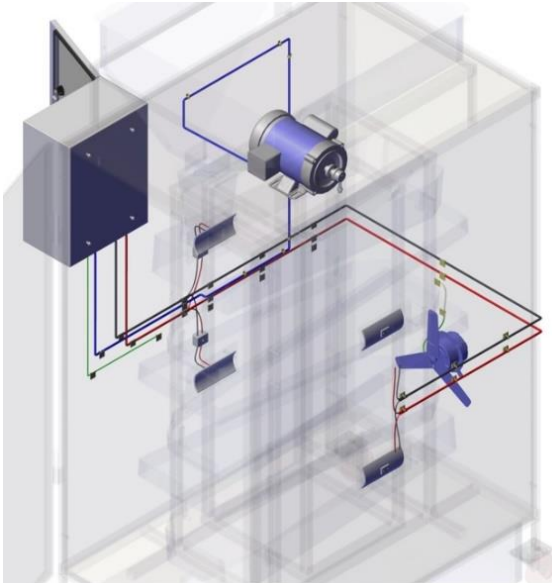
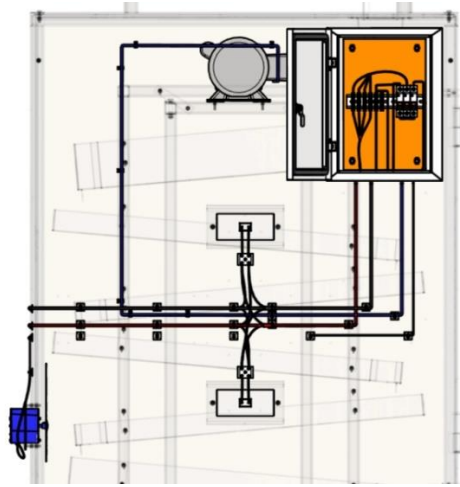

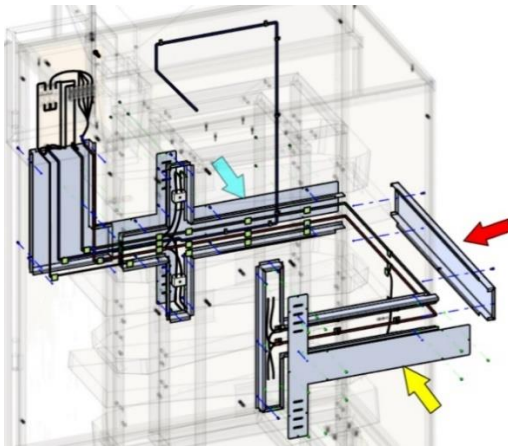

**Duct fitting as wire enclosure on wire fittings.**  
[VA2021-P004-03-0005](#), [VA2021-P004-03-0006](#), [VA2021-P004-03-0007](#), [VA2021-P004-03-0008](#), [VA2021-P004-03-0009](#), [VA2021-P004-03-0010](#)

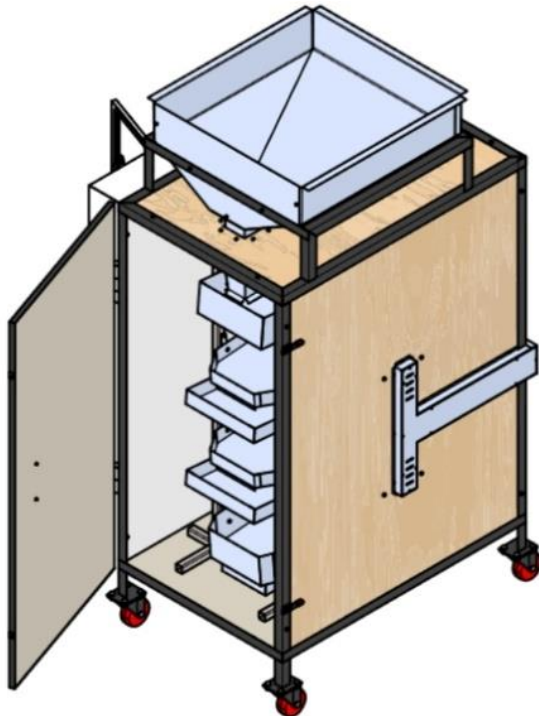



## 11. Commissioning of system

- Make a Bending properly for fabrication of sheet metal parts
- Make a welding properly for fabrication of Heating chamber & passage duct
- Make holes on sheet properly at specified positions.
- Wiring as shown in the block diagram of electronics components connections must be proper to short circuit & mis functioning.
- Door should be leak proof.
- Use Foam as a insulating material.

## 12. Maintenance of system

- Check electrical supply & wiring condition for proper functioning of Heater & Fan.
- Check the Heater condition after three months of use (or as recommended by the Battery manufacturer)
- Disconnect the power supply & clean up the cabinet properly once in a month.

## 13. Disclaimer

The content in this DIY manual is the developed by Vigyan Ashram. All instructions are merely for educational purpose and to create a sharable open-source D-I-Y document.

While the information in this document has been verified to the best of our abilities, we cannot guarantee the performance. All the observation and data are taken from various experiments on system at Vigyan Ashram.

We reserve the right to change the design. Please contact our website or our expert team for any clarification.