

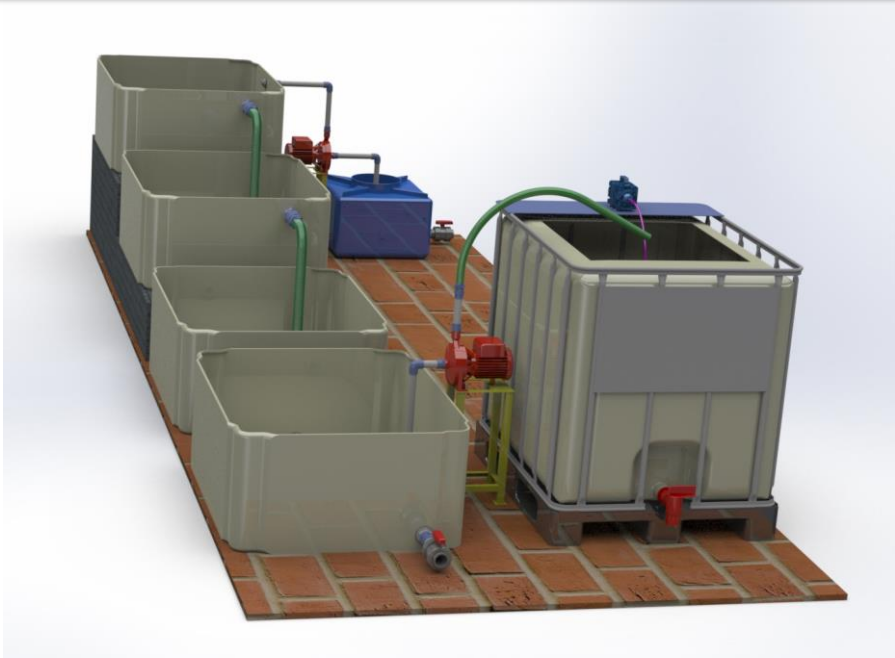

**VIGYAN  
ASHRAM**

## **1000 L MODULAR GREY WATER SYSTEM**



# **Do-It-Yourself Manual**

Supported by:

 **DASSAULT  
SYSTEMES**  
— La Fondation —

# INDEX

1. Introduction
2. Purpose of Project
3. Safety Instructions
4. Product Description
5. Features
6. Parts for purchase
7. Tools Required
8. How it Works? - Grey Water
9. Step by Step Installation
10. Commissioning of System
11. Maintenance of System
12. Disclaimer

# 1. Introduction

Vigyan Ashram has designed & developed a “1000 L Modular Grey Water System” for schools / small houses/ bungalows. Users of the manual will be able to build their own grey water system using this manual. All the Bills of Materials (BOM) and dimensions of the systems are given in the design. We have provided designs files drawn using Solidworks along with this manual. Users are suggested to read the manual carefully along and assess the site conditions before fabrication of the unit.

Please watch following video carefully:

- <https://www.youtube.com/watch?v=P9vIStr7R44>
- <http://vigyanashram.online/project/grey-water/>
- [https://drive.google.com/file/d/1MAgtWjnrq\\_\\_YpkHpXQtZXT61Y1FLODuC/view?usp=sharing](https://drive.google.com/file/d/1MAgtWjnrq__YpkHpXQtZXT61Y1FLODuC/view?usp=sharing)

## 2. Purpose of Manual

- To share standardized design of grey water systems suitable for small bungalows, hamlets, schools and institutes.
- To reduce cost of construction of reed bed systems using readily available IBC tanks.
- Design to be made available online for local fabricators to build grey water systems for their customers.

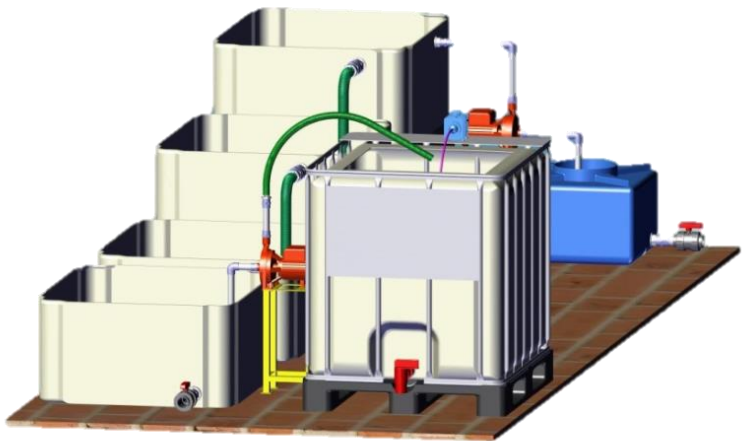

### 3. Safety Instructions

During fabrication of the system we should use safety equipment such as hand gloves, shoes and glasses.



(And as appropriate)

## 4. Product Description

This is a 1000L modular grey water system. This system can be deployed on plain ground, no excavation needed. Tanks to be arranged at elevation of 2 feet and 1 feet respectively from ground level to get the benefit of gravity for water flow.

System consists of a sludge tank, four 500L IBC tanks with reeds bed, two pumps of 0.25 HP for water circulation, piping connections and 1000L IBC for water storage.

The proposed system is able to reduce **COD** (chemical oxygen demand) of output water to **20-100 mg/L** (ppm- Parts Per Million) and **DO** (Dissolve Oxygen) greater than **2**.

The detail view and bill of materials are given below:

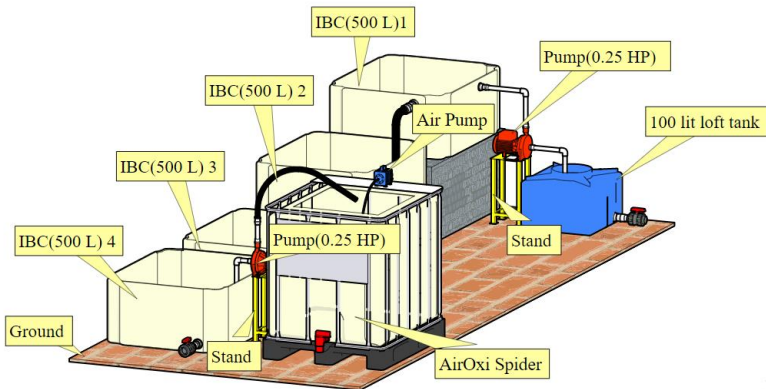

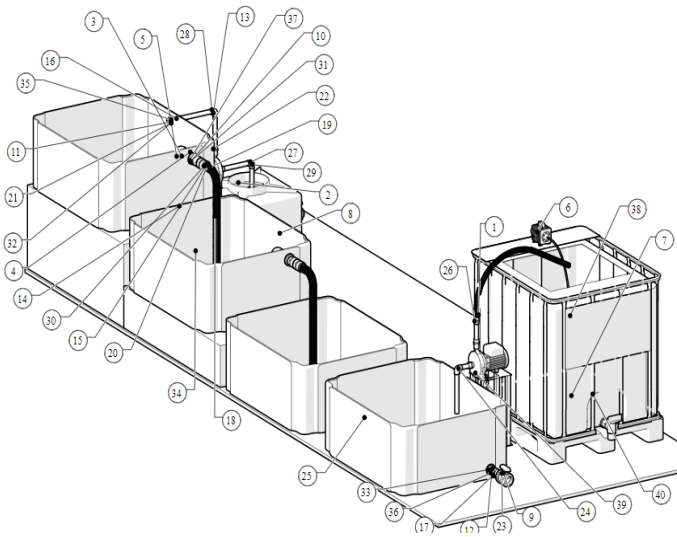
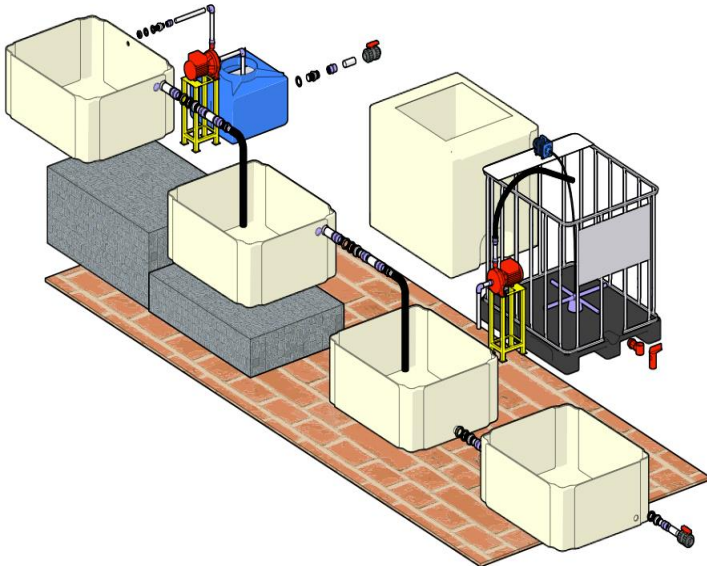

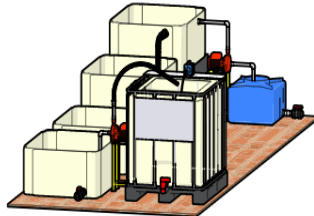

BOM ID	Description	Qty	BOM ID	Description	Qty
1	1 inch nipple	1	22	MTA(1")	4
2	100 lit loft tank	1	23	PVC Pipe (100mm)	2
3	2 inch elbow	2	24	PVC Pipe (100mm)(1')	1
4	2 inch pipe (100 mm)	4	25	PVC Pipe (150 mm) (2')	1
5	2 inch pipe (300mm)	2	26	PVC Pipe (200mm)(1')	1
6	Air Pump	1	27	PVC Pipe (250mm)(1')	2
7	AirOxi Spider	1	28	PVC Pipe (300mm)(1')	2
8	Baffel	2	29	PVC Pipe (400mm)(1')	1
9	Ball Valve(1.5")	2	30	Pump(0.25 HP)	2
10	Coller (2")	5	31	Rubber Washer (2")	10
11	Coller(1")	1	32	Rubber Washer(1")	2
12	Coller(1.5")	2	33	Rubber Washer(1.5")	4
13	Elbow (DIN 8063) 90 Deg Type W1	3	34	Stand	2
14	End Cap (3")	2	35	Tank Nipple(1")	1
15	FTA (2")	9	36	Tank Nipple(1.5")	2
16	FTA(1")	2	37	Tank nipple (2")	5
17	FTA(1.5")	2	38	Tube-375X049'Tube_1-1000 lit Gray water system-003-1	1
18	Flexible pipe	3	39	hhs(grade c) is	2
19	G.I.Nipple	2	40	tank	1
20	Hose Clip	3			
21	IBC	4			

- <https://drive.google.com/file/d/1esVehgPq6fL-NgIw3QPO6PhV0cBmGllT/view?usp=sharing>
- [https://drive.google.com/file/d/1z13UREPHsilNa\\_fZP4Fau-q\\_dXvXc-0WK/view?usp=sharing](https://drive.google.com/file/d/1z13UREPHsilNa_fZP4Fau-q_dXvXc-0WK/view?usp=sharing)
- <https://drive.google.com/file/d/1KMO0qix08UIQB0lVzWrjavKj-mqG5iTn/view?usp=sharing>
- [https://drive.google.com/file/d/1Vx\\_ZRwjQ4mYs\\_l0gs3u-OSyyMuHyzaxvT/view?usp=sharing](https://drive.google.com/file/d/1Vx_ZRwjQ4mYs_l0gs3u-OSyyMuHyzaxvT/view?usp=sharing)



## 5. Features

- Capacity: 1000 L/day
- Total area required:  $(6\text{mtrs} * 2.4\text{mtrs}) = 14.4\text{mtr}^2 \sim 157\text{sq. feet.}$
- Recycle water use:
  - Gardening
  - Toilet Flushing





**NOTE:** Recycled water from this system is not for drinking purposes.

## 6. Parts for purchase

<u>Sr.No</u>	Part Name	Dimensions	Material	Qty.
1.	IBC(1000 L)	1m*1m	PP	3
2.	Tank Nipple	1"	U-PVC	1
		1 1/2"		2
		2"		5
3.	F.T.A. (Female Threaded Adapter)	1"	PVC	2
		1 1/2"		2
		2"		9
4.	M.T.A. (Male Threaded Adapter)	1"	PVC	4
		1 1/2"		0
		2"		0
5.	End Cap	1"	U-PVC	0
		2"		0
		3"		2
6.	Valve	1"	PVC	0
		1 1/2"		2
		2"		0
7.	Elbow	1"	PVC	3
		1 1/2"		0
		2"		2
8.	PVC Pipe	1"	PVC	7 ft
		1 1/2"		2ft
		2"		5 ft

9.	Flexible Pipe	1"	HDPE	1m
		1 1/2"		2m
		2"		0
10.	G.I Nipple	1"	G.I.	1
		1 1/2"		2
		2"		0
11.	Hose clip	1"	M.S.	1
		1 1/2"		2
		2"		0

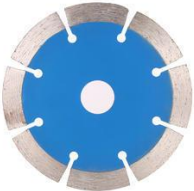
## 7. Tools required

Sr. No.	Tool	Image
1.	Hand Grinder	
2.	Drill Machine	
3.	Cutter wheel	
4.	Hole saw	

5.	Self-Screw Bit	
6.	Single Sided Pipe Wrench	
7.	Hack Saw	

## 8. How it works? - Grey Water

There are two kinds of domestic waste water – black water and grey water. Black water is the one which is released from the toilets whereas grey water is from the bathroom & from the kitchen.

The amount of grey water generated depends on the individual's consumption of freshwater. The water used for washing hands, vegetables, and dishes or even for bathing can easily be recycled to bridge the ever increasing demand and supply gap.

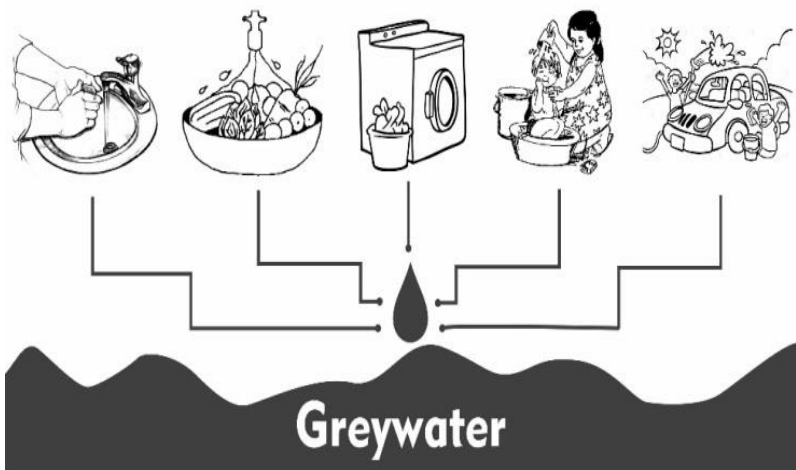

## How to recycle grey water?

- Usually our houses are built in a way that black water and grey water get mixed. To avoid this, separate pipelines are needed to isolate the discharge of both these kinds of waste water.
- While the black water can go into the drain, grey water pipe can be diverted to a small sludge tank where all such water gets collected.
- While water from the bathroom will contain things like hair, oil, and soap sediments, water from the kitchen sink might have small quantities of food items like rice, lentils or other such contents.

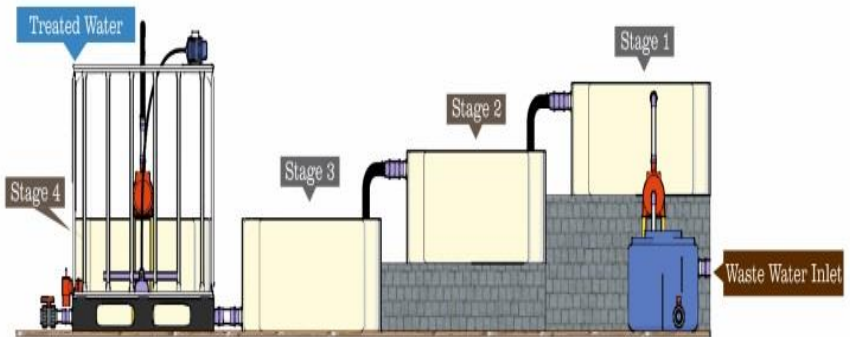

- Once grey water is collected separately, the next step is to pass through reed beds for filtration. After the filtration process, grey water is collected in the storage tank and is given excessive bubbling. After this process grey water is fit to be used for gardening or flushing purposes.



## 9. Step by Step installation

Step 1: IBC (500 L) Preparation

Step 2: Ground & Elevation Preparation

Step 3: Sludge Tank (100 L)

Step 4: IBC 1(500 L)

Step 5: IBC 2(500 L)

Step 6: IBC 3(500 L)

Step 7: IBC 4(500 L)

Step 8: Pump & Stand 1

Step 9: Pump & Stand 2

Step 10: Storage Tank & Air Pump

## Step 1: IBC (500 L) Preparation

Once you have 1000L IBC tanks cut it from middle and convert into two 500L IBC,



## Step 2: Ground & Elevation Preparation

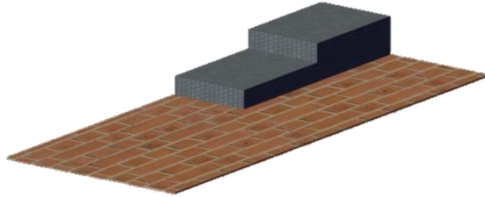

- Please prepare the ground with the levels required to put IBC tanks.
- For levels bricks or cement block like materials are required for preparing level.
- We need to ensure there are no sharp stones in the basement of the IBC tank.
- To mark the outline 6m\*2.4m dimension for system are given below,

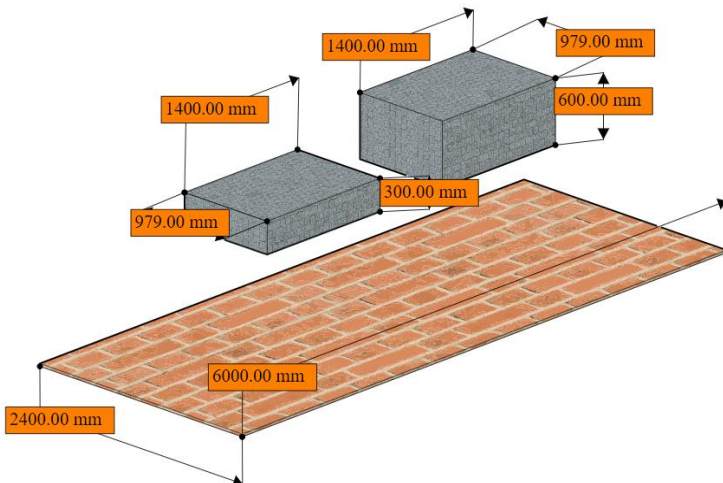

### Step 3: Sludge Tank (100 L)

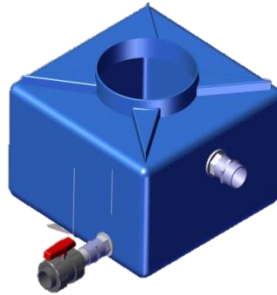

- Sludge tank contains two compartments. One for settlement of sludge & another for screening water.
- Please use the fittings and pipes to sludge tank.
- IBC pipe fitting can be done as follows :

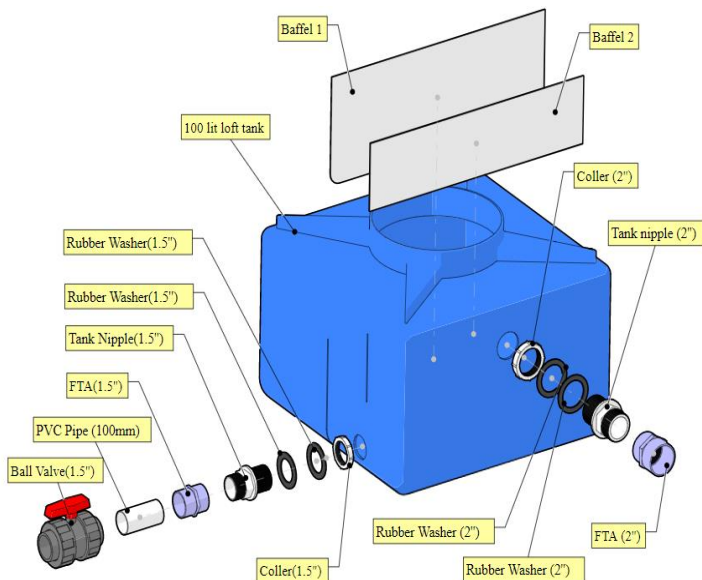

BOM ID	Description	Qty
1	100 lit loft tank	1
2	Baffle	2
3	Ball Valve(1.5")	1
4	Coller (2")	1
5	Coller(1.5")	1
6	FTA (2")	1
7	FTA(1.5")	1
8	PVC Pipe (100mm)	1
9	Rubber Washer (2")	2
10	Rubber Washer(1.5")	2
11	Tank nipple (2")	1
12	Tank Nipple(1.5")	1

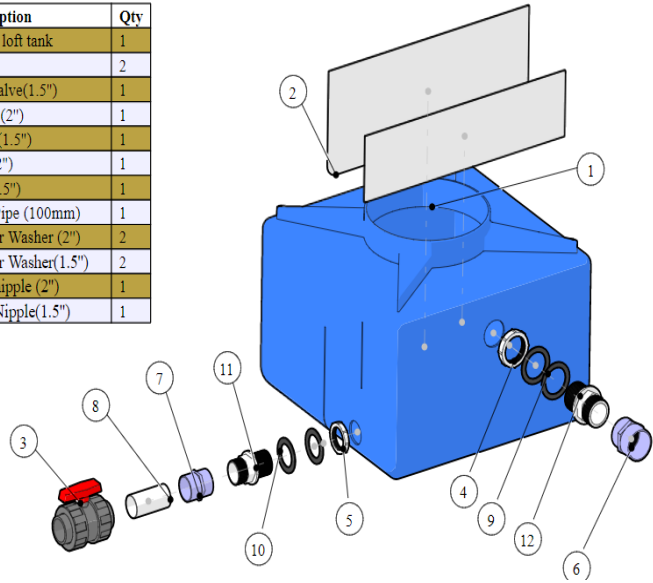

- <https://drive.google.com/file/d/1Gdl5Gwu1UOr12-pUHDpsusOKU1Z-CjMu/view?usp=sharing>
- <https://drive.google.com/file/d/1sFQOacAjwjcPnV1Y2elk6WddqVesf5H8/view?usp=sharing>
- <https://drive.google.com/file/d/1rJHRMk0CvsGGop1WatTXT8oXhnsNX3k4/view?usp=sharing>
- <https://drive.google.com/file/d/1DEs8jM5vcFpfuWOMijRpFEMxgLkHt8Y/view?usp=sharing>

## Step 4: IBC 1(500 L)

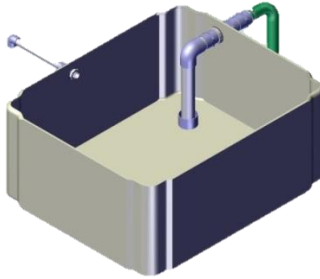

- IBC 1 has two pipes connections, one from the sludge tank on the right side wall and the other on the right upper side, towards IBC 2.
- Please use the fittings and pipes to IBC 1 are as follows:

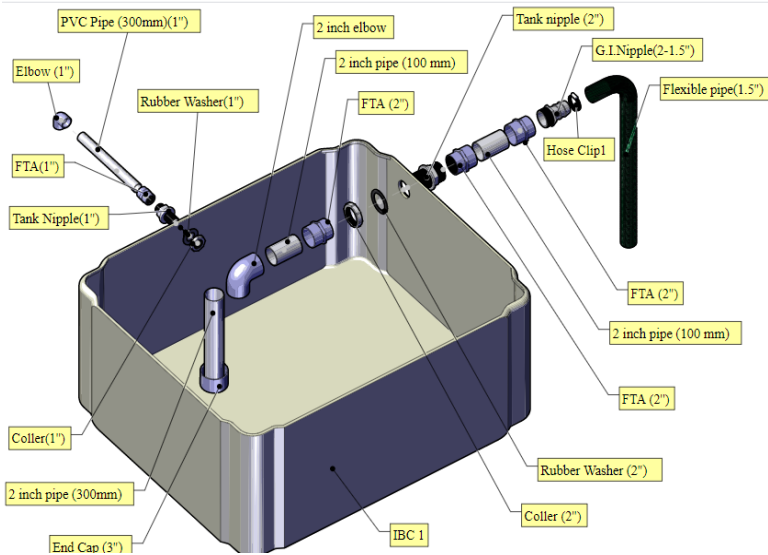

BOM ID	Description	Qty
1	2 inch elbow	1
2	2 inch pipe (100 mm)	2
3	2 inch pipe (300mm)	1
4	Coller (2")	1
5	Coller (1")	1
6	Elbow (DIN 8063) 90 Deg Type W1	1
7	End Cap (3")	1
10	Flexible pipe 1	1
8	FTA (2")	3
9	FTA (1")	1
11	G.I Nipple	1
12	Hose Clip1	1
13	IBC 1	1
14	PVC Pipe (300mm)(1")	1
15	Rubber Washer (2")	2
16	Rubber Washer (1")	2
18	Tank nipple (2")	1
17	Tank Nipple(1")	1

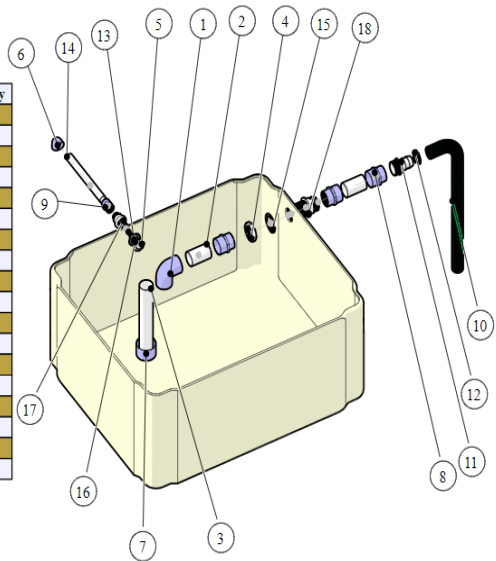

- <https://drive.google.com/file/d/1JH3RobHuxgcKCCVHVQ3gMDBp14B17E39/view?usp=sharing>
- <https://drive.google.com/file/d/1wiVmUeU7ogTZx-mDMConKZ6XkfXl3Xic/view?usp=sharing>
- [https://drive.google.com/file/d/1AFr\\_TS6Oi4\\_mXgMXiCoNxv-dUAuedR\\_x/view?usp=sharing](https://drive.google.com/file/d/1AFr_TS6Oi4_mXgMXiCoNxv-dUAuedR_x/view?usp=sharing)
- [https://drive.google.com/file/d/1sE8JGzOkvz-Now8q58\\_MOO9FzxbZT3O2/view?usp=sharing](https://drive.google.com/file/d/1sE8JGzOkvz-Now8q58_MOO9FzxbZT3O2/view?usp=sharing)

## Step 5: IBC 2(500 L)

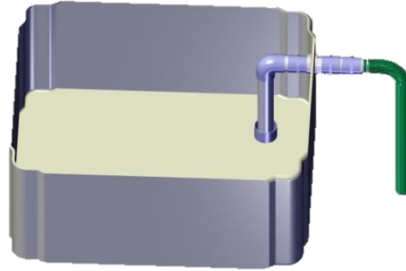

- IBC 2 having pipes connected right upper side on front wall, towards IBC 3.
- Connect water transferring pipe fitting as shown below.

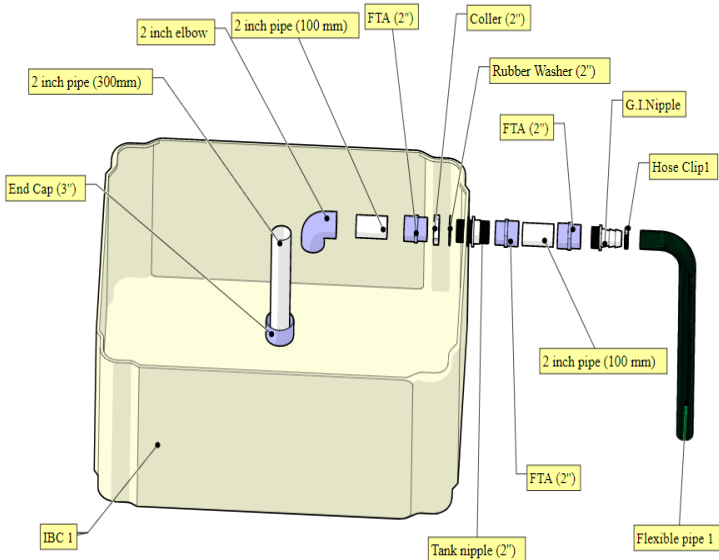



BOMID	Description	Qty
1	2 inch elbow	1
2	2 inch pipe (100 mm)	2
3	2 inch pipe (300mm)	1
4	Coller (2")	1
5	End Cap (3")	1
7	Flexible pipe 1	1
6	FTA (2")	3
8	G.I.Nipple	1
9	Hose Clip1	1
10	IBC 1	1
11	Rubber Washer (2")	2
12	Tank nipple (2")	1

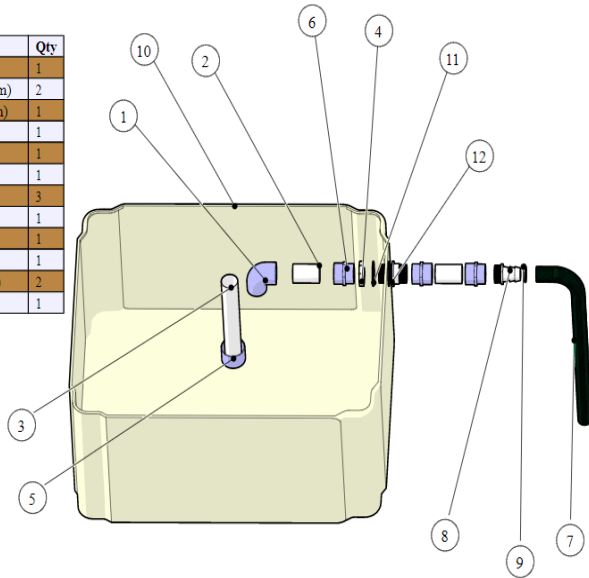

- <https://drive.google.com/file/d/1Xq9XIL6KhL6sY-jT6QAO1069NGf4mv4L/view?usp=sharing>
- <https://drive.google.com/file/d/119GWNuUdDgPoi0wvsyGhyTb0bDdNZopv/view?usp=sharing>
- <https://drive.google.com/file/d/140qcsHqDkIohoCYAauOITjF9idaltbBt/view?usp=sharing>
- <https://drive.google.com/file/d/18RdnrFHwjSI6oCNK4NONhezLEtAzWjVV/view?usp=sharing>

## Step 6: IBC 3(500 L)

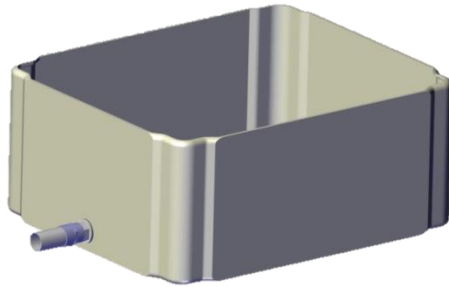

- IBC 3 having centrally pipe connection at bottom from wall side towards IBC 4.
- Connect water transferring pipe fitting as shown below.

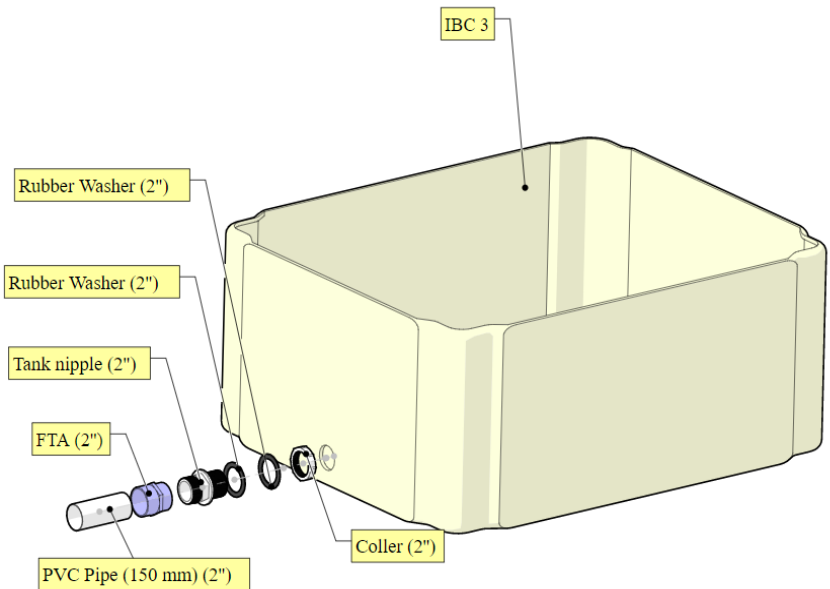

BOM ID	Description	Qty
1	Coller (2")	1
2	FTA (2")	1
3	IBC 3	1
4	PVC Pipe (150 mm) (2")	1
5	Rubber Washer (2")	2
6	Tank nipple (2")	1

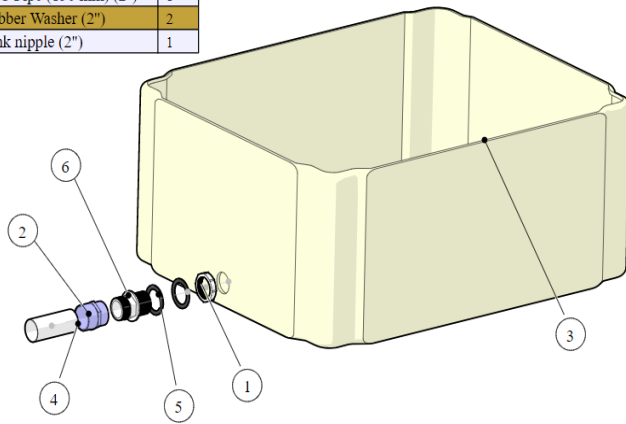

- <https://drive.google.com/file/d/19ASQOB2poikAiRSGQgjlB-CD0pjaUB5s/view?usp=sharing>
- <https://drive.google.com/file/d/1kx2q5FXqJornBw48XUblkwFNr4Xe16iU/view?usp=sharing>
- [https://drive.google.com/file/d/13yHPdqSCbi36pctx19p9LW\\_qUUOkOgBO/view?usp=sharing](https://drive.google.com/file/d/13yHPdqSCbi36pctx19p9LW_qUUOkOgBO/view?usp=sharing)
- [https://drive.google.com/file/d/1O94agWWdNFy-YncEnJ\\_MiNI6cz7xOGjc/view?usp=sharing](https://drive.google.com/file/d/1O94agWWdNFy-YncEnJ_MiNI6cz7xOGjc/view?usp=sharing)

## Step 7: IBC 4(500 L)

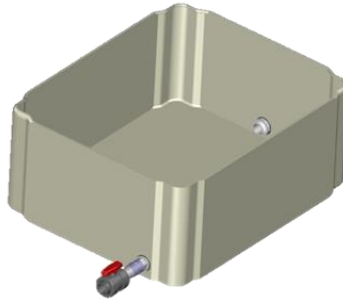

- IBC 4 having two pipe connections.
- One is at bottom back wall side & another at bottom right corner of front wall side.
- Connect water transferring pipe fitting as shown below:

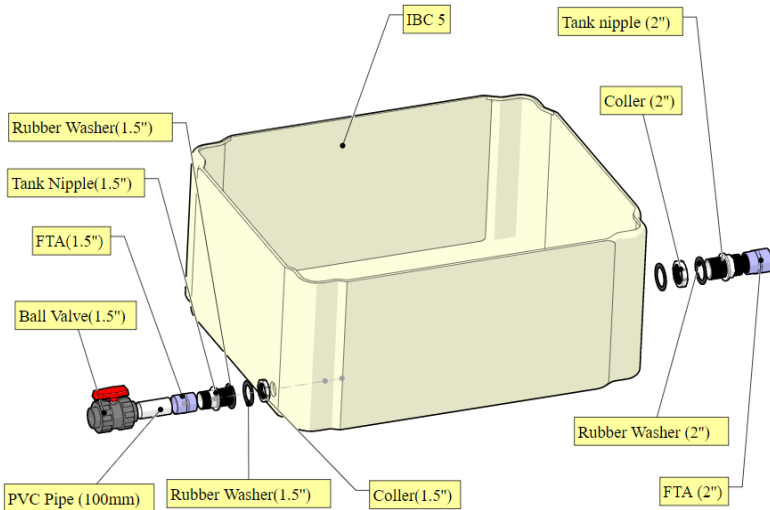

BOM ID	Description	Qty
1	Ball Valve(1.5")	1
2	Coller (2")	1
3	Coller(1.5")	1
4	FTA (2")	1
5	FTA(1.5")	1
7	PVC Pipe (100mm)	1
8	Rubber Washer (2")	2
9	Rubber Washer(1.5")	2
11	Tank nipple (2")	1
10	Tank Nipple(1.5")	1

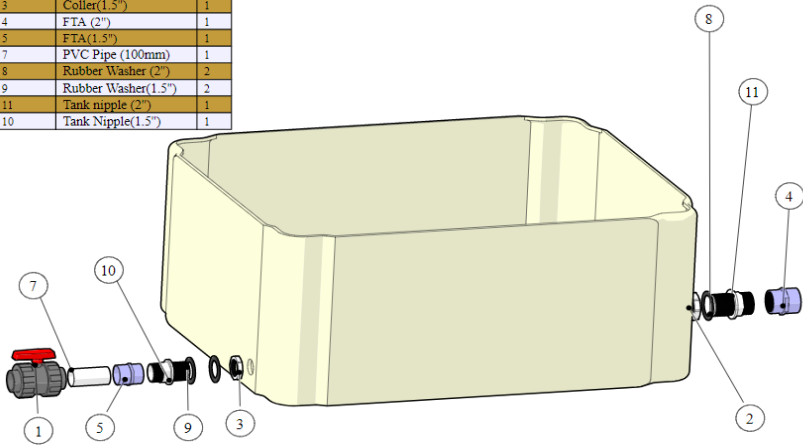

- <https://drive.google.com/file/d/1iXMRqpJS5HN74n17AfbJdgXPp7hvPiQ-/view?usp=sharing>
- <https://drive.google.com/file/d/1y9v1OHMwQARXiVY9XY1De17-m4mOTR28/view?usp=sharing>
- [https://drive.google.com/file/d/19vWee7XofqD8IYis\\_AtoW1AM0kLRN8L/view?usp=sharing](https://drive.google.com/file/d/19vWee7XofqD8IYis_AtoW1AM0kLRN8L/view?usp=sharing)
- <https://drive.google.com/file/d/1LgBwcr5pH4y7yQYHAA8NBxwGzYZcybvY/view?usp=sharing>

## Step 8: Pump & Stand 1

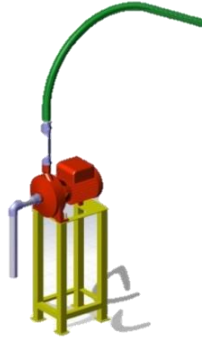

- Pump and stand 1 transfer water from IBC 4 to the Storage tank.
- At inlet of pump having PVC piping & outlet Flexible pipe.
- Pipe fitting can be done as follows :

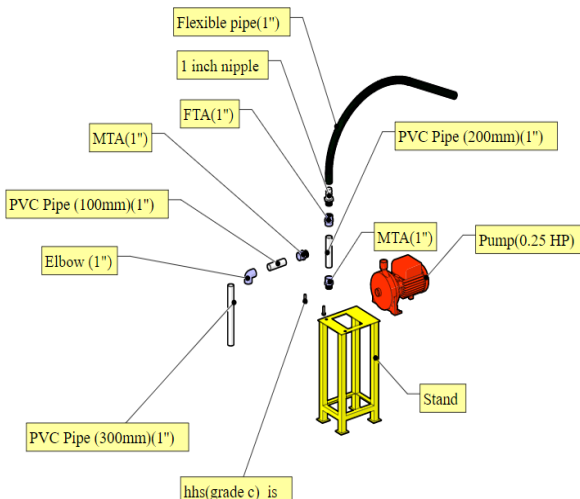

BOM ID	Description	Qty
1	1 inch nipple	1
2	Elbow (DIN 8063) 90 Deg Type W1	1
3	FTA(1")	1
4	Flexible pipe 2	1
5	MTA(1")	2
6	PVC Pipe (100mm)(1")	1
7	PVC Pipe (200mm)(1")	1
8	PVC Pipe (300mm)(1")	1
9	Pump(0.25 HP)	1
10	Stand	1
11	hhs(grade c) is	2

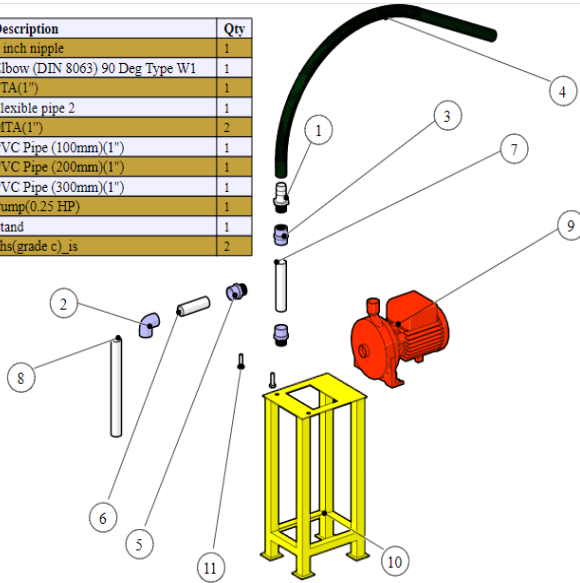

- <https://drive.google.com/file/d/1Nnq5x7PiBcXKnY5WgTitlNkxFMzwUQSC/view?usp=sharing>
- <https://drive.google.com/file/d/1lig8CboG-QYHMwCTWAlJ7xiaXnPO9rsO/view?usp=sharing>
- <https://drive.google.com/file/d/1pwVece2ZUNRrZJF9V0XlxOXdYDtu-jlS/view?usp=sharing>
- <https://drive.google.com/file/d/1QRMs6HJ79VrjMzA86do1CRpp3PHxXYn2/view?usp=sharing>

## Step 9: Pump & Stand 2

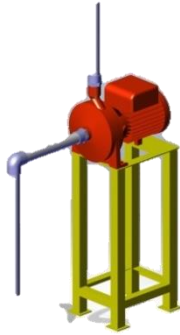

- Pump and stand 2 transfer water from Sludge tank to IBC 1.
- At the inlet & outlet of the pump having PVC piping. Pipe fitting can be done as follows:

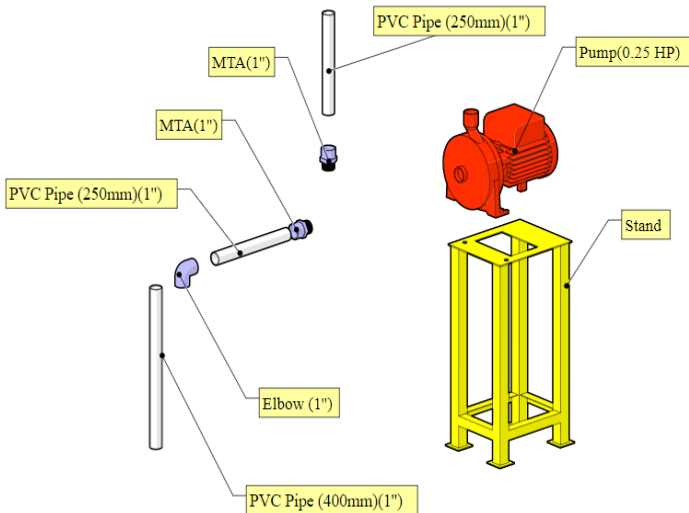



BOM ID	Description	Qty
1	Elbow (DIN 8063) 90 Deg Type W1	1
2	MTA(1")	2
5	Pump(0.25 HP)	1
3	PVC Pipe (250mm)(1')	2
4	PVC Pipe (400mm)(1')	1
6	Stand	1

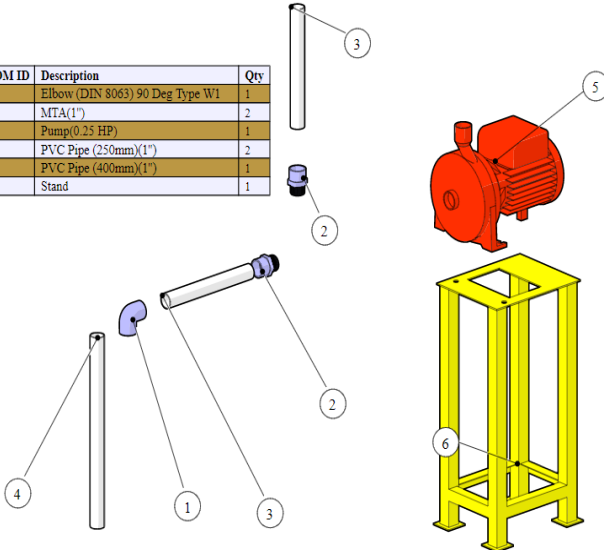

- [https://drive.google.com/file/d/1E\\_GoJy1MMLiKS0v80q7qdXiC4esUZUp/view?usp=sharing](https://drive.google.com/file/d/1E_GoJy1MMLiKS0v80q7qdXiC4esUZUp/view?usp=sharing)
- <https://drive.google.com/file/d/1fu33YaAn-Awv3kiXstEtGbVRujZrLL0s/view?usp=sharing>
- <https://drive.google.com/file/d/1appeekP4RDB5BMAz8FwBNL4oAtWaYjVn/view?usp=sharing>
- [https://drive.google.com/file/d/1Xox\\_p2ZIU6lUFt7KTKkkAwBqRIsCJn/view?usp=sharing](https://drive.google.com/file/d/1Xox_p2ZIU6lUFt7KTKkkAwBqRIsCJn/view?usp=sharing)

## Step 10: Storage Tank & Air Pump

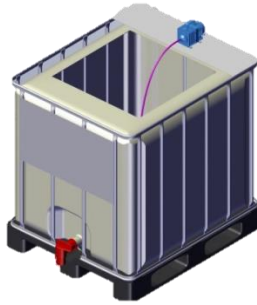

- Storage Tank contains AirOxi Spider and Air pump for bubbling purposes.
- Connections can be done as follows :

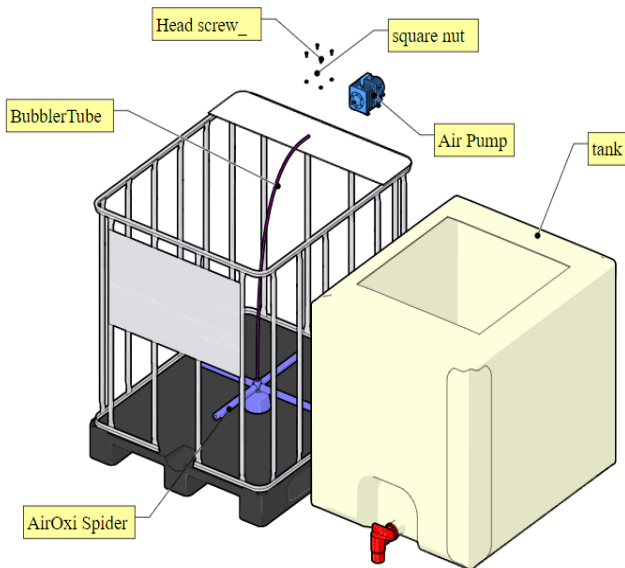

BOM ID	Description	Qty
1	tank	1
2	Air Pump	1
3	AirOxi Spider	1
4	Tube-375X049°Tube_1-1000 lit Gray water system-003-1	1

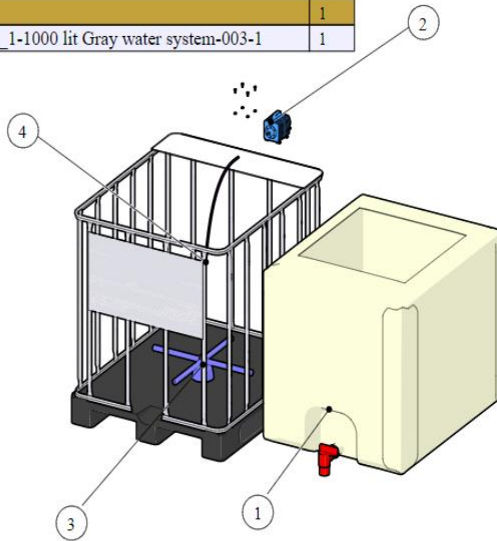

- <https://drive.google.com/file/d/18Njb61UX2fZq9T0EKHJqqMAdmkdrBBma/view?usp=sharing>
- <https://drive.google.com/file/d/1tAXv5aYTIIMGDHAua3K4A-Ghh7ZozX3/view?usp=sharing>
- [https://drive.google.com/file/d/1t6zoo\\_orEA1Zog1RR1J9Sajr5XI\\_CDh8/view?usp=sharing](https://drive.google.com/file/d/1t6zoo_orEA1Zog1RR1J9Sajr5XI_CDh8/view?usp=sharing)
- <https://drive.google.com/file/d/1MMiuEyUCcQy5xPChdSax5jmaYo0GkA3/view?usp=sharing>

## 10. Commissioning of system

- To convert 1000L IBC into 500L tanks cut it properly at the middle from the foot valve.
- Make holes on walls of cut IBC properly at specified positions.
- Plumbing as shown in the diagram of pipe connections must be proper to avoid leakages from joints.
- Use small pieces of bricks as a reed bed.
- To prepare corridors to cut IBC at pipe joints.
- 1000L Storage IBC should be leak proof.

## 11. Maintenance of system

- First one month is required for system activation; afterward's check COD (Chemical Oxygen Demand) & DO (Dissolved Oxygen) of water in the storage tank once in two months.
- The Sludge tank should be clean once a month to avoid buildup of odors and possibility of choking. If the first section of the sludge tank is 50% filled, open up the foot valve immediately.
- The IBC 1, 2, 3 & 4 clean all inlet and outlet sections once a month to avoid choking.
- Check electrical supply for proper functioning of water pumps and air pump.
- Ensure continuous air bubbling for the storage tank.

## 12. Disclaimer

The content in this DIY manual is the developed by Vigyan Ashram. All instructions are merely for educational purpose and to create a sharable open source D-I-Y document.

While the information in this document has been verified to the best of our abilities, we cannot guarantee the performance. All the observation and data are taken from various experiments on system at Vigyan Ashram.

We reserve the right to change the design. Please contact our website or our expert team for any clarification.