



**VIGYAN
ASHRAM**

60 PLANTS HYDROPONICS SYSTEM



Do-It-Yourself Manual

Supported by:

 **DASSAULT
SYSTEMES**
— La Fondation —

INDEX

1. Introduction
2. Purpose of Project
3. Safety Instructions
4. Product Description
5. Features
6. Parts for purchase
7. Tools Required
8. How it Works? – Hydroponics System
9. Step by Step Installation
10. Commissioning of System
11. Maintenance of System
12. Disclaimer

1. Introduction

Vigyan Ashram has designed & developed a “Hydroponics System” for schools / small houses/ bungalows. Users of the manual will be able to build their own Hydroponics Structure using this manual. All the Bills of Materials (BOM) and dimensions of the systems are given in the design. We have provided designs files drawn using Solidworks along with this manual. Users are suggested to read the manual carefully along with the site conditions before fabrication of the unit.

Please watch following video carefully:

- https://www.youtube.com/watch?v=kJHpBa-0Ddo&feature=emb_logo
- <https://www.youtube.com/watch?v=G8JrYJYUg88>
- <https://www.youtube.com/watch?v=tWYvxtKyp9k>
- https://www.youtube.com/watch?v=bTIq_S3jwRc

2. Purpose of Manual

- To share standardized design of Hydroponics Structure suitable for small bungalows, hamlets, schools and institutes.
- Design to be made available online for local fabricators to build Hydroponics Structure for their customers.



3. Safety Instructions

During fabrication of the system we should use safety equipment such as hand gloves, shoes and glasses.



(And as appropriate)

4. Product Description

This is a Hydroponics Structure. This system can be deployed on plain ground, no construction needed.

System consists of a 50L storage tank, six PVC (2'') pipes with sixty net pots, submersible pump of 18 W for nutrient solutions circulation, piping connections and shade net roof.

The proposed system is able to grow sixty plants at a time.

The detail view and bill of materials are given below:

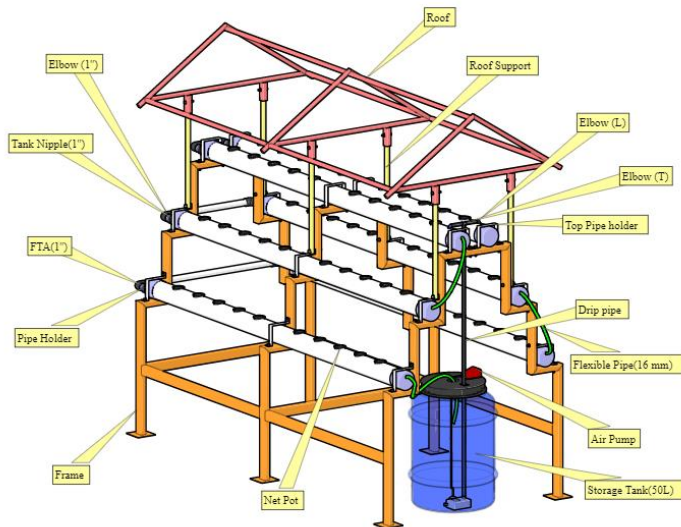

- <https://drive.google.com/file/d/1esVehgPq6fL-NgIw3QPO6PhV0cBmGIIT/view?usp=sharing>
- https://drive.google.com/file/d/1z13UREPHsilNa fZP4Fau-q_dXvXc-0WK/view?usp=sharing
- <https://drive.google.com/file/d/1KMO0qix08UIQ B0lVzWrjavKj-mqG5iTn/view?usp=sharing>
- https://drive.google.com/file/d/1Vx_ZRwjQ4mYs l0gs3u-OSyyMuHyzaxvT/view?usp=sharing

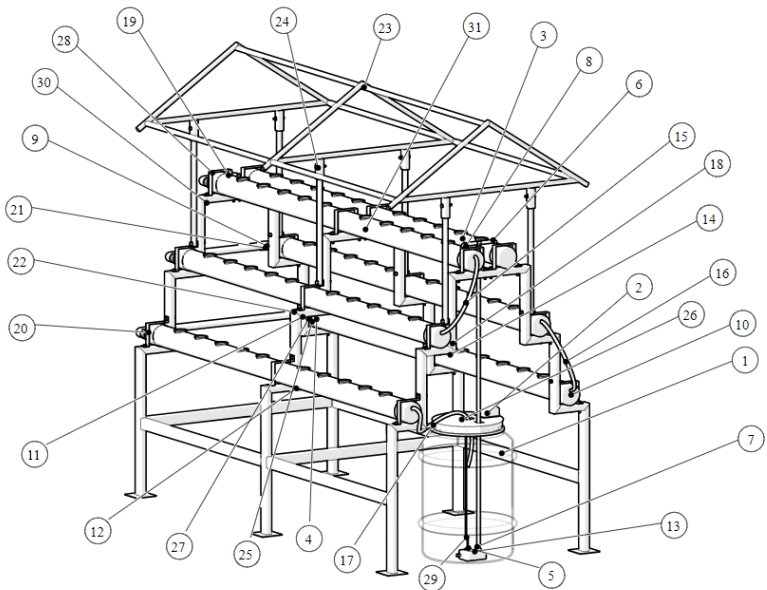

BOM ID	Description	Qty
1	50Lit Tank	1
2	Air Pump	1
3	Cup	60
4	Coller(1")	6
5	Diffuser	1
6	Drip pipe	2
7	Drip pipe - Copy	1
8	Elbow	3
9	Elbow (DIN 8063) (1")	6
10	End Cap(3")	12
11	FTA(1")	6
12	Frame	1
13	Pump	1
14	PVC Pipe	6
15	Part1^Hydroponics Structure-1	1
16	Part1^Hydroponics Structure-1	1
17	Part4^Hydroponics Structure-1	1
18	Pipe Holder	12
19	Pipe(1") 121mm	1
20	Pipe(1") 40mm	6
21	Pipe(1") 467mm	1
22	Pipe(1") 767mm	1
23	Roof 2	1
24	Roof Support	6
25	Rubber Washer(1")	12
26	Tank Cap	1
27	Tank Nipple(1")	6
28	Top Pipe holder	6
29	Tube-218X028_1^Tube_1-Hydroponics Structure-005-1	1
30	hexagon thin nut (uc) is	42
31	hhs(grade c) is	42

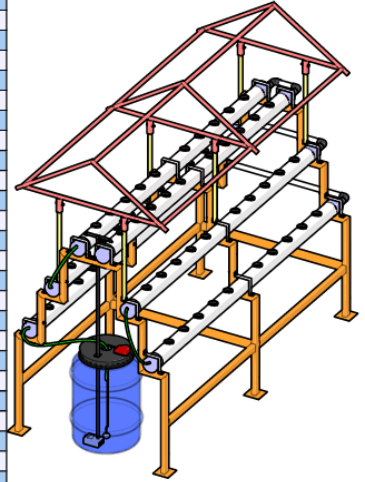

5. Features

- Capacity: 60 Plants
- Total area required: $(2.16\text{mtrs} * 1.01\text{mtrs}) = 2.18\text{mtr}^2 = 21.52\text{sq. feet} \sim 21.52\text{ sq. feet}$
- Method Used: Flood & Drain
- Compact System
- Use:
 - Terrace Farming
 - Kitchen Gardening

NOTE: There is no conclusive evidence that produce grown hydroponically are more nutritious or healthier than produce grown by any other method.

6. Parts for purchase

Sr. No.	Part Name	Dimensions	Materials	Qty.
1.	Tank Nipple	1''	U-PVC	6
2.	F.T.A. (Female Threaded Adapter)	1''	PVC	6
3.	End Cap	3''	PVC	12
4.	PVC Pipe	3''	PVC	43 ft.
5.	Drip pipe	16mm	HDPE	8 ft.
6.	Elbow (L)	16mm	HDPE	2
7.	Elbow (T)	16mm	HDPE	1
8.	Flexible pipe	16mm	HDPE	5 ft.
9.	Shade net	100 GSM	HDPE	3.5 m ²
10.	Net pot	50mm*70mm	HDPE	60

7. Tools required

Sr. No.	Tool	Image
1.	Hand Grinder	
2.	Drill Machine	
3.	Power cutter	
4.	Welding Machine	

5.	Protractor	
6.	Measuring Tape	
7.	Drill pipe drill bit	
4.	Hole saw	
7.	Hack Saw	

8. How it works? - Hydroponics

Hydroponics is a type of horticulture and a subset of hydro culture, which is a method of growing plants, usually crops, without soil, by using mineral nutrient solutions in an aqueous solvent

Hydroponics has been recognized as a viable method of producing vegetables (spinach, Dill, tomatoes, lettuce, cucumbers and peppers) as well as ornamental crops such as herbs, roses, freesia and foliage plants

Advantages

- It can be used in places where in-ground agriculture or gardening is not possible (for example, dry desert areas or cold climate regions).
- More complete control of nutrient with water and nutrient recycling.
- Faster growth due to more available oxygen in content, pH and growing environment.
- Lower water and nutrient costs associated root area.
- Elimination or reduction of soil related insects, fungi and bacteria.
- Much higher crop yields.
- No weeding or cultivation required.

- Some crops, such as lettuce and strawberries, can be lifted from ground level to a much better height for planting, cultivation and harvesting. This gives much better working conditions and hence lowers labor costs.
- Crop rotation/fallowing is not necessary.
- Transplant shock is reduced

Disadvantages

- Initial and operational costs are higher than soil culture.
- Skill and knowledge are needed to operate properly

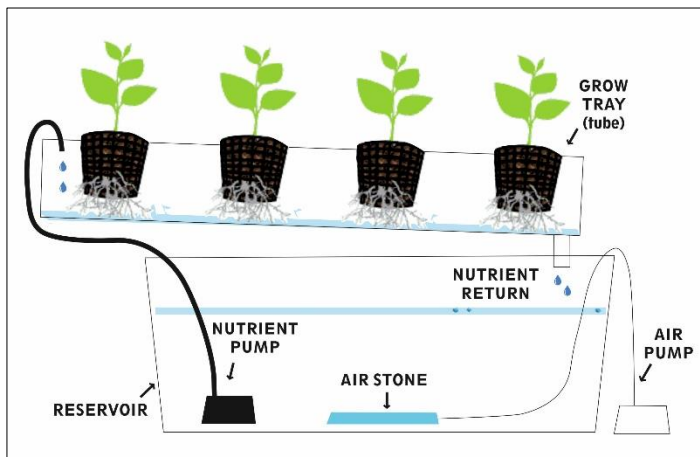

- Nutrient Film Technique (NFT): Plants are placed in a polyethylene tube that has slits cut in the plastic for the roots to be inserted. Nutrient solution is pumped through this tube.

NFT Systems have a constant flow of nutrient solution, so no timer is required for the submersible pump

9. Step by Step installation

Step 1: Frame Preparation

Step 2: Roof preparation

Step 3: PVC pipe & End Cap cutting

Step 4: Pipe Holders

Step 5: PVC pipe-1 assembly

Step 6: PVC pipe-2, 3,4,5,6 assembly

Step 7: Storage Tank, Air Pump & submersible pump

Step 1: Frame Preparation

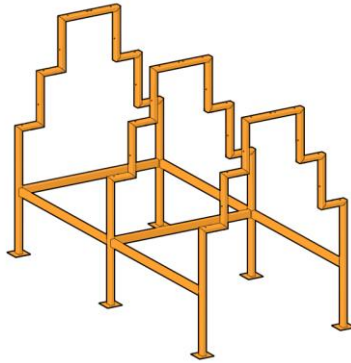

- Frame structure contains six parts using 50*30 Rectangular Tube & join it together with welding.
- The detail drafted drawings are as follows,
- <https://drive.google.com/file/d/1PiPydIMeXDVqKi4umz-50tbQohJRoZIS/view?usp=sharing>
- https://drive.google.com/file/d/16USVQ_CTNBBanUPN7GS3tf5HdG_YfhcI/view?usp=sharing
- https://drive.google.com/file/d/1ZKGnt_63sqS1idW3t_9mbbTNG3tstY9Y/view?usp=sharing
- https://drive.google.com/file/d/1nX6KRmilb3B_iZiQ0kvg_i_EpVs2oJRH/view?usp=sharing
- <https://drive.google.com/file/d/15PT9KCLi3AuTnCuV5MymIjjaJqbnVIF/view?usp=sharing>
- <https://drive.google.com/file/d/1VFK-M3LxRZ93OhBmszgAo86viod87-X9/view?usp=sharing>
- https://drive.google.com/file/d/1vI34Z3GzuyIE_1s8DOVgLrnZkFmLp0iJ/view?usp=sharing

Step 2: Roof preparation

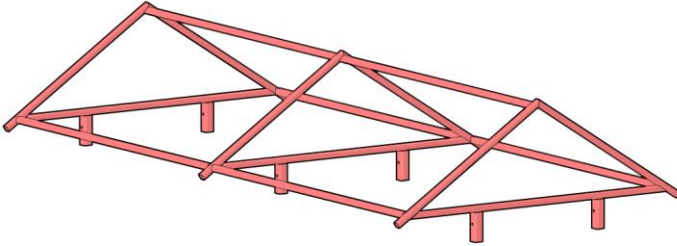

- Frame structure contains 20*20, 25*25 Square tube & 25*3 L-Angle join it together with welding.
- The detail drafted drawings are as follows,
- <https://drive.google.com/file/d/1BxbarXiMT4AUJ2FHJ2BvGLisNTA46GIG/view?usp=sharing>
- <https://drive.google.com/file/d/1muOjQEUvqlmy4AZo0FxFzHLTpeewl-yb/view?usp=sharing>
- https://drive.google.com/file/d/1cCRmz22sbGpoSbBRq_MiI4yuGI-v2GCL/view?usp=sharing
- <https://drive.google.com/file/d/1z5mqhM1qHkD0k674EulkfytzVL0ITY-C/view?usp=sharing>
- https://drive.google.com/file/d/1jiY4OUXxl6ACj1R_fQUeD4I2G-q52e5/view?usp=sharing
- https://drive.google.com/file/d/1qsw0nXioDaopTQENZ_aSg-5PvSd3m6-5/view?usp=sharing
- https://drive.google.com/file/d/1BY4ODOy_1E2fSNDpWbpq6QkOfaelrKTK/view?usp=sharing
- <https://drive.google.com/file/d/1eAbvjIjqS0domjXUUCSye0yB0bMrOT9Q/view?usp=sharing>

Step 3: PVC pipe & End Cap cutting



https://drive.google.com/file/d/1xSK63xluAnIy7365_iNTdSP7ufTBb4Ew/view?usp=sharing

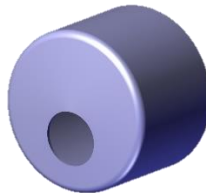

https://drive.google.com/file/d/16ItZ8IPHD_VgYdNkRTkTmaNqQKq920Ez/view?usp=sharing

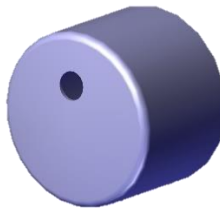

<https://drive.google.com/file/d/1BVfdQIn9dfvIPs0dIJOQtKh5CF68TPw1/view?usp=sharing>

Step 4: Pipe Holders



<https://drive.google.com/file/d/1BcDcmRa4qiTumtaLdelPJLob2xw-46Ab/view?usp=sharing>



<https://drive.google.com/file/d/15SL1QrPz8MYsTADGqBiwYOKiUiYgUKWB/view?usp=sharing>

Step 5: PVC pipe 1 assembly

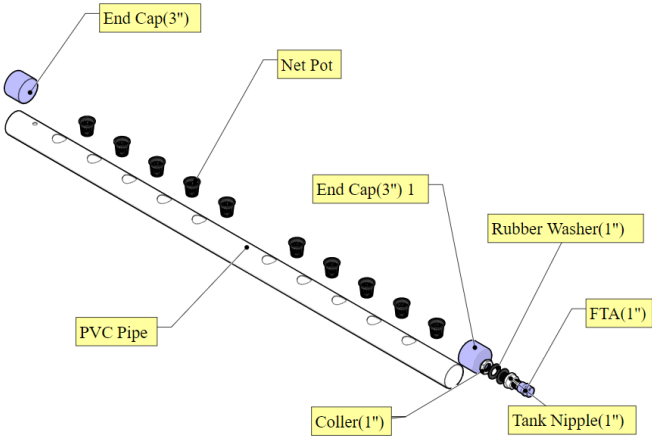

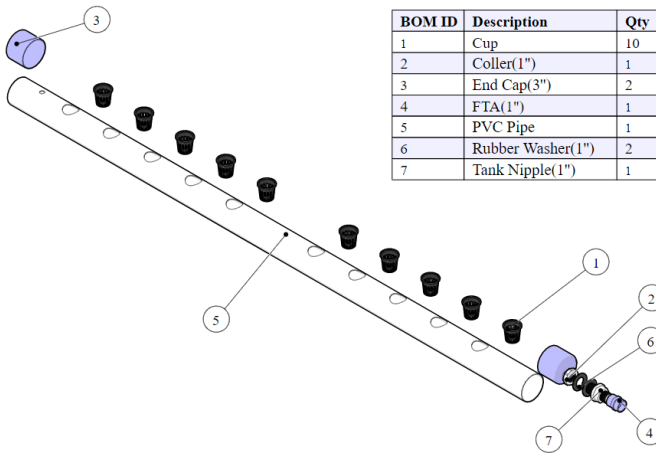

- <https://drive.google.com/file/d/148dLKpv85srm4hfGyxZ290elqgY81bkV/view?usp=sharing>
- https://drive.google.com/file/d/1I_xKjmAtfv2E7khCfWnD2MwkEdCYp0Kr/view?usp=sharing
- <https://drive.google.com/file/d/1srGHNESdMA19OAzIsV88Pj4MlrSIYfeB/view?usp=sharing>
- https://drive.google.com/file/d/1y_Wq_F8qiDWpMg1BsxF6pB2wPRJ2QsPO/view?usp=sharing

Step 6: PVC pipe-2, 3,4,5,6 assembly

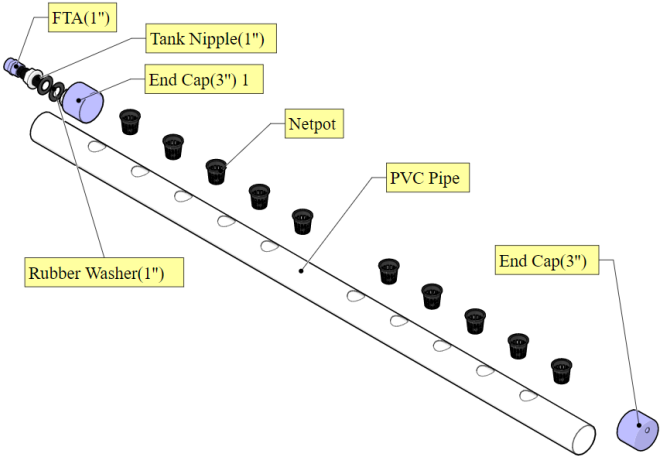

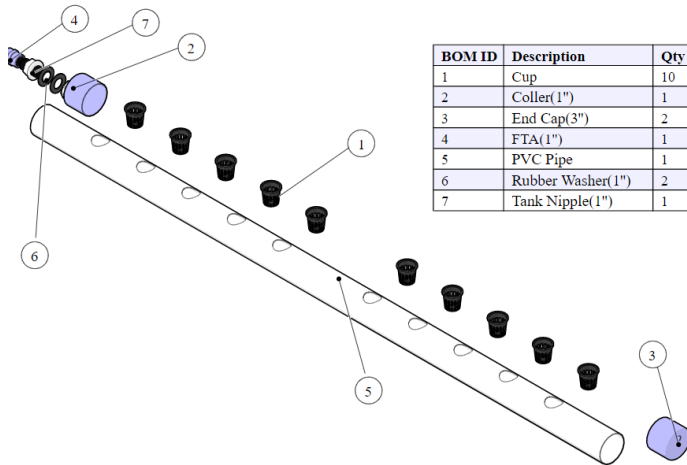

BOM ID	Description	Qty
1	Cup	10
2	Coller(1")	1
3	End Cap(3")	2
4	FTA(1")	1
5	PVC Pipe	1
6	Rubber Washer(1")	2
7	Tank Nipple(1")	1

- <https://drive.google.com/file/d/1ZJbL1jh3TTpNYDedmwJGV66rEZ5OXw8L/view?usp=sharing>
- https://drive.google.com/file/d/1P04S72p3DFzsMNfcW_hbcTNiGQIN_g-a/view?usp=sharing
- <https://drive.google.com/file/d/1Ri4QS36dU8MeSPo7EXe5JFA-CqsJ4lNa/view?usp=sharing>
- https://drive.google.com/file/d/1KYGw_B7UXEHONgoScXcQ4XEIwj_H9ZT1/view?usp=sharing

Step 7: Storage Tank, Air Pump & submersible pump

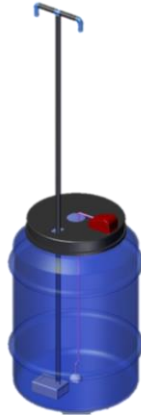

- Storage Tank contains Submersible pump with drip piping and Air pump for bubbling purposes.
- Connections can be done as follows :

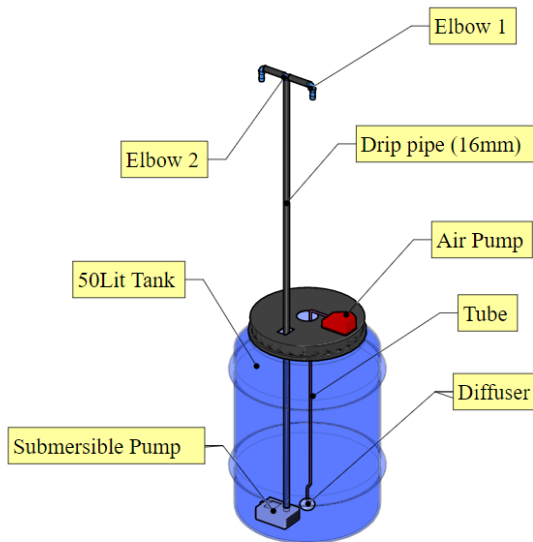

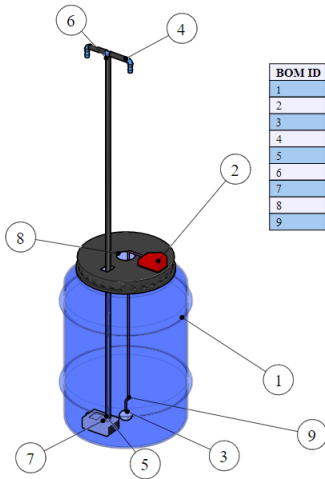

BOM ID	Description	Qty
1	50Lit Tank	1
2	Air Pump	1
3	Diffuser	1
4	Drip pipe	2
5	Drip pipe - Copy	1
6	Elbow	3
7	Pump	1
8	Tank Cap	1
9	Tube-218X028_1'Tube_1-Hydroponics Structure-005-1	1

- <https://drive.google.com/file/d/1JpEvU-FKs-34H3b2pOckyDVT8nqEEO5T/view?usp=sharing>
- https://drive.google.com/file/d/13R1j8155qdZt_1MqMIxcgCaBvzVJVtjH/view?usp=sharing
- <https://drive.google.com/file/d/11uVe-Qoc2I7n8hIDDZzsgPh0nWE50900/view?usp=sharing>
- <https://drive.google.com/file/d/1YDV772q3gJIK5t2x8dLau7sbk-7mcXWT/view?usp=sharing>

7. Commissioning of system

- Make a welding properly for fabrication of Frame & Roof.
- Make holes on PVC Pipes & End Caps properly at specified positions.
- Plumbing as shown in the diagram of pipe connections must be proper to avoid leakages from joints.
- Storage PVC pipes should be leak proof.
- Use cockpit & coir (Kathya) in Net pots as a bed.
- Flexible pipe should be deep into water.

11. Maintenance of system

- First 10 days are required for system activation; check EC (Electrical Conductivity), TDS (Total Dissolved Solids) of water before & after fertigation (Fertilizer Dosing).
- First harvesting would take 15 days, afterword's harvesting cycle requires 7 days.
- Fertigation (Fertilizer Dosing) cycle required 7 days.
- Clean up the PVC pipes properly once in a month to avoid chocking of flexible pipes.
- To Avoid Pest & disease attack spraying of pesticide & fungicide should be done.
- Check electrical supply for proper functioning of water pumps and air pump.

12. Disclaimer

The content in this DIY manual is the developed by Vigyan Ashram. All instructions are merely for educational purpose and to create a sharable open source D-I-Y document.

While the information in this document has been verified to the best of our abilities, we cannot guarantee the performance. All the observation and data are taken from various experiments on system at Vigyan Ashram.

We reserve the right to change the design. Please contact our website or our expert team for any clarification.